

# QLS10T

## SPECIFICATIONS

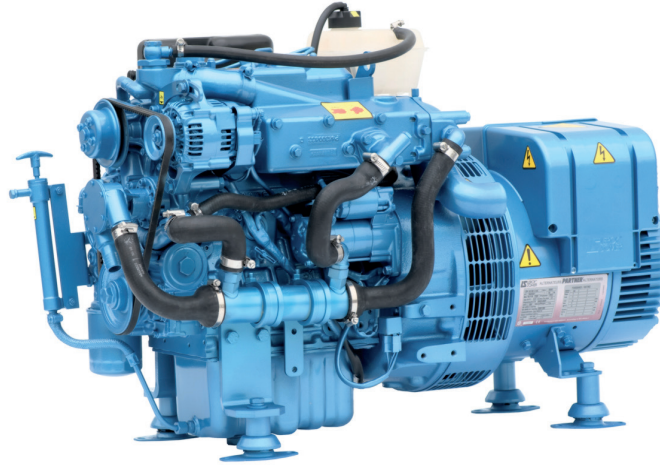

Frequency	50 Hz	Engine base	Kubota
Voltage	400 V	Cooling system	Seawater pump with rubber impeller
Amperes	12.6 A cont. 14.3 A max.	Closed cooling	Heat exchanger
Power	7.0 kW cont. 7.9 kW max.	Cylinders	3 in line
Protection	IP23	Start (cold temperature)	Super Glow System
Insulation	Class H	Exhaust connexion	50 mm [2 in]
Voltage accuracy	± 1.5%	Fuel consumption at full load	2.3 l/h [0.61 gal US/h]
Radio interference	Deleted	Sea water pump connexion	25 mm [1 in]
Length	959 mm [36.8 in]	Fuel pump - Max suction height	std pump : 0.5 m [19.7 in] with add. pump : 1.8 m [70.9 in]
Width	489 mm [19.3 in]	Engine operating angle	15° cont. 30° max.
Height	624 mm [24.6 in]	Fuel connexion	8 mm [0.3 in]
Dry weight	251 kg [553.4 lbs]	Class approval	Bureau Veritas

# QLS10T

7.9 kW max at 1500 rpm

## TECHNICAL DESCRIPTION

### ENGINE BASE

- 4 strokes Diesel engine tested in all marine or industrial applications throughout the world.
- Engine block in cast iron type tunnel and timing gear.

### INJECTION AND COMBUSTION SYSTEM

- The Super Glow System comes as standard equipment to start the engine in cold temperatures.
- The E-TVCS injection system produces an ideal air/fuel mixture by creating three vortices in the combustion chamber. The combustion efficiency is improved, resulting in low fuel consumption.

### COOLING SYSTEM

- Cooling is ensured by heat exchange between coolant and seawater in a heat exchanger, or via a Keel Cooling system.
- Seawater pump with rubber impeller.

### GENERATOR

- Delivering a continuous power of 7.0 kW and able to provide up to 7.9 kW
- IP23 protection

### STANDARD EQUIPMENT

- Extension delivered by meter
- Closed cooling with heat exchanger
- Wet exhaust
- 12V Single-pole electrical system
- Safety shutdowns on low oil pressure and high coolant temperature
- Eco GE panel
- Rubber mounts
- Oil drain pump mounted on the engine

### OPTIONAL EQUIPMENT

- Seawater hoses
- Seawater filter
- Siphon breaker
- Fuel feed system piping
- Exhaust system
- Fuel prefilter
- Keel Cooling
- Vertical dry exhaust
- 12V Double-pole electrical system
- Luxe GE panel (instead of Eco GE panel)
- Additional electric fuel feed pump

## INSTRUMENT PANEL

### ECO GE



### LUXE GE



- Start and stop buttons
- Low oil pressure warning light
- Coolant temperature warning light
- Preheat warning light
- Battery charge warning light
- Oil pressure indicator \*
- Coolant temperature indicator \*

\*Only with Luxe GE

## MAIN COMPONENTS

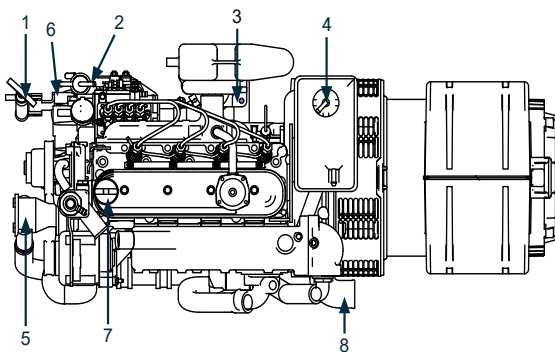

- |                   |                    |
|-------------------|--------------------|
| 1. Oil drain pump | 5. Seawater pump   |
| 2. Fuel feed pump | 6. Oil filter      |
| 3. Fuel filter    | 7. Oil filter port |
| 4. Expansion tank | 8. Exhaust elbow   |

### NANNI INDUSTRIES S.A.S.

11, Avenue Mariotte - Zone Industrielle  
33260 La Teste - France  
Tel: +33 (0)5 56 22 30 60  
Fax: +33 (0)5 56 22 30 79

Technical data according to ISO 8528. This document is not contractual. Nanni reserves the right to modify any of the characteristics stated in this document without notice, in a constant effort to improve the quality of its products. Images and illustrations may show non standard equipments. All combination of equipment & accessory are not available.

DGBXXC01151