

# N4.80

## SPECIFICATIONS

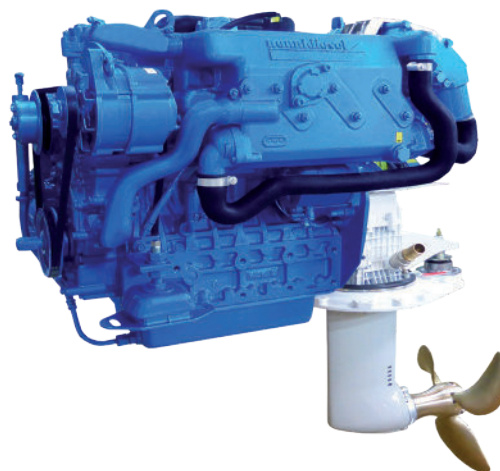
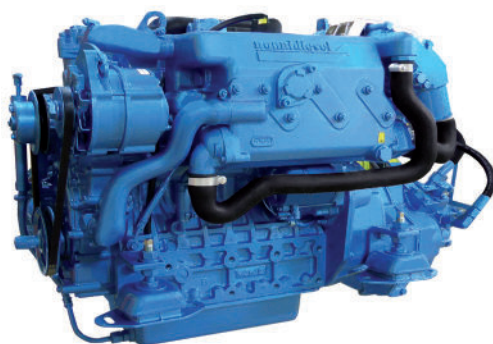

Power at crankshaft shaft line sail drive	57.4 kW [79 hp] 52.9 kW [72 hp]
Displacement	2.434 l [148.5 in <sup>3</sup> ]
Configuration	4 cylinders in line
Operation type	4 strokes Diesel
Bore & Stroke	87 x 102.4 mm [3.43 x 4.03 in]
Compression ratio	23 : 1
Rated speed	2700 rpm
Idling speed	850 rpm
Peak torque	220 Nm
Peak torque speed	1800 rpm

Engine base	Kubota
Fuel system	Indirect E-TVCS (Three Vortex Combustion System)
Air intake	Turbocharger & Intercooler
Cooling	Closed cooling with heat exchanger Air cooler
Max mounting angle shaft line sail drive	7° Front down / 7° Front up 15° Front down / 15° Front up
Alternator	12 Volt 120 Amp
Rating	M5
Emission compliance	EPA marine Tier 3 RCD2013/53/EU BSO2
Dry weight with TM345A with SD12	275 kg [606.3 lbs] 296 kg [652.6 lbs]

# N4.80

## TECHNICAL DESCRIPTION

### ENGINE BLOCK AND HEAD

- 4 Cylinders in line
- 2 Valves per cylinder
- Gear driven valve train
- Watercooled exhaust manifold
- Cylinder block and cylinder head manufactured from high grade cast iron. Crankcase features a rigid tunnel block design.
- Chrome molybdenum forged crankshaft, statically and dynamically balanced with integral counterweights. Pistons are cast from high silicon aluminum, are heat treated and fitted with two cast iron, chromium faced compression rings and a single oil ring
- Replaceable, hardened valve seats
- Elastic coupling on flywheel
- Engine mounting tuned front and rear cushion-type rubber mounts. Adjustable.

### FUEL SYSTEM

- Indirect E-TVCS injection system
- Fuel filter
- Feed pump with hand primer
- Spin-on type fine fuel filter
- Auxiliary stop lever on engine

### LUBRICATION SYSTEM

- Spin-on full-flow oil filter
- Oil dipstick
- Closed circuit crankcase ventilation
- One top oil filling position

### COOLING SYSTEM

- Closed cooling with heat exchanger
- Gear driven self-priming raw water pump
- Coolant circulating pump
- Freshwater cooled exhaust manifold and water cooled exhaust elbow
- Freshwater cooling system governed by thermostat
- Tubular heat exchanger with integral expansion tank
- Easily accessible sea water pump and impeller

### ELECTRICAL SYSTEM & INSTRUMENTATION

- 12 V electrical system
- 120 A marine alternator
- Complete instrumentation including key switch and alarms
- Extension cable harness with plug-and-play
- Charging regulator with electronic sensor for voltage drop compensation
- Electric starter motor (2.0 kW output)
- Electrical stop

### AIR INTAKE

- Turbocharged with intercooler

### OTHER FEATURES

- Single side serviceability

### OPTIONAL EQUIPMENTS & ACCESSORIES

- 24V alternator as option
- Dry exhaust elbow
- Complete marine propulsion systems
- Marine transmission adaptation kits
- Throttle and shift controls
- Additional instrumentation, Flying bridge extension harness
- Rigid engine mounting
- Power take off
- Separate instruments for fuel level, temperature and voltage
- Option **Sl4** : NMEA interactive control displays, intuitive, interactive and the most tiny of all controllers (170x104mm)



### RATINGS

- Up to 1000 annual operating hours
- Load factor up to 35%
- Full power for no more than 30 minutes out of each 8 hours of operation. The remaining time must be at, or below cruising speed
- Recreational boats, tactical military vessels and rescue boats

### TRANSMISSIONS

#### SHAFT LINE

- TM345A

#### SAIL DRIVE

- SD12
- Option **SPP12**: pivoting leg, joystick maneuvering, plug and play components and electric pre-wired parts



- Contact your Nanni representative for more details and availability about transmissions types and model range.

## PERFORMANCE CURVES

### POWER AT CRANKSHAFT

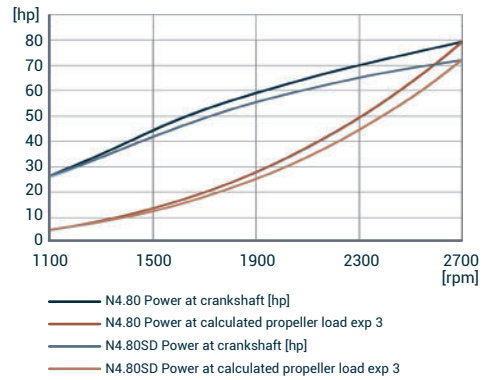

### TORQUE AT CRANKSHAFT

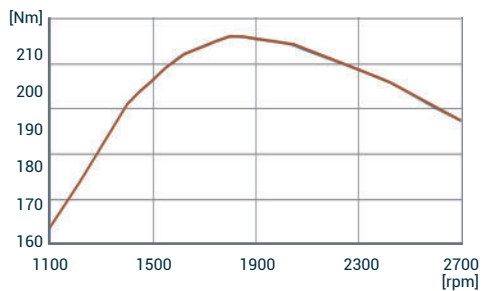

### FUEL CONSUMPTION

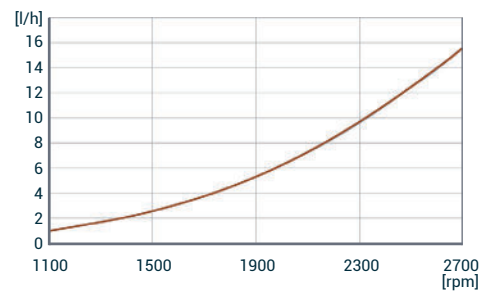

## DIMENSIONS SHAFT LINE & SAIL DRIVE

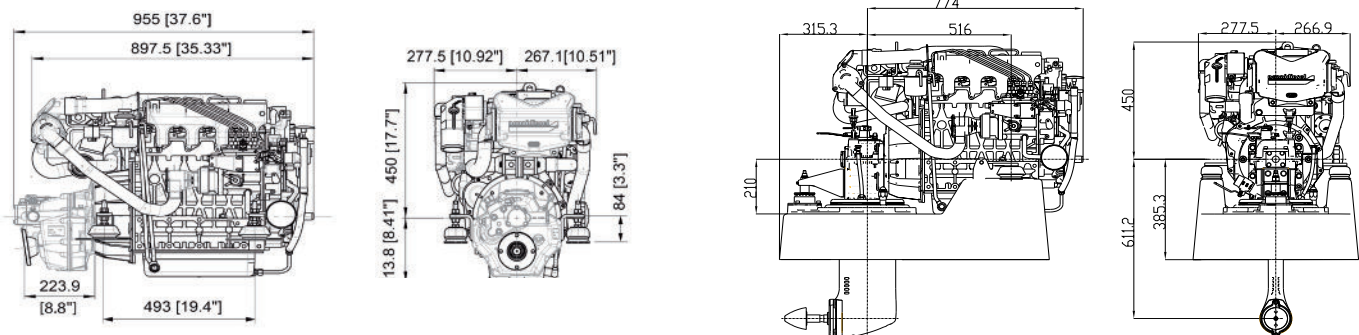

## NANNI INDUSTRIES S.A.S.

11, Avenue Mariotte - Zone Industrielle  
 33260 La Teste - France  
 Tel: +33 (0)5 56 22 30 60  
 Fax: +33 (0)5 56 22 30 79

Technical data according to ISO 8665. This document is not contractual. Nanni reserves the right to modify any of the characteristics stated in this document without notice, in a constant effort to improve the quality of its products. Images and illustrations may show non standard equipments. All combination of equipment & accessory are not available.

DGBXXC01009A