

# N6.230

## SPECIFICATIONS

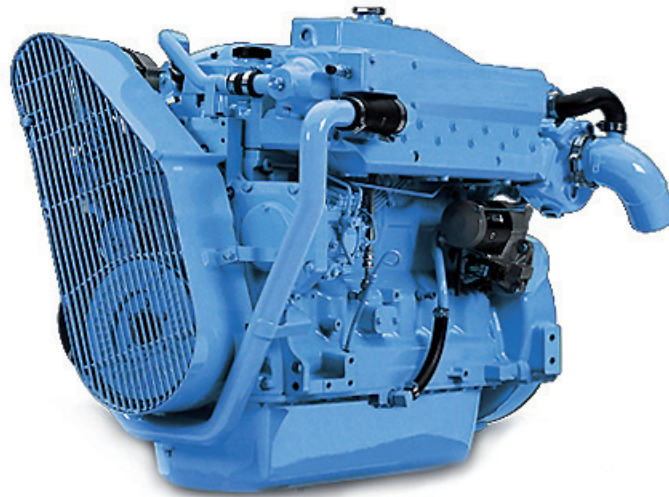

Power at crankshaft	168 kW [228 hp]	Engine base	John Deere
Displacement	6.8 l [415 in <sup>3</sup> ]	Fuel system	Direct injection Mechanical governor
Configuration	6 cylinders in line	Air intake	Turbocharged
Operation type	4 strokes Diesel	Cooling	Closed cooling with heat exchanger
Bore & Stroke	106.4 x 127 mm [4.19 x 5 in]	Max mounting angle	0° Front down 9° Front up
Compression ratio	16.3 : 1	Alternator	24 Volt 50 Amp
Rated speed	2600 rpm	Rating	M4
Idling speed	650 rpm	Dry weight	735 kg [1620 lbs]
Peak torque	784 Nm	Peak storque speed	1800 rpm

# N6.230

168 kW [228 hp] at 2600 rpm

## TECHNICAL DESCRIPTION

### ENGINE BLOCK

- Replaceable wet-type cylinder liners
- Watercooled exhaust manifold

### FUEL SYSTEM

- Fuel filter
- Direct injection, mechanical governor

### LUBRICATION SYSTEM

- Replaceable full-flow oil filter
- Oil dipstick
- Oil cooler

### COOLING SYSTEM

- Closed cooling with heat exchanger
- Gear driven self-priming raw water pump
- Coolant circulating pump
- Water cooled exhaust elbow

### ELECTRICAL SYSTEM & INSTRUMENTATION

- 24V / 50A alternator
- 24V starter motor
- Complete instrumentation including key switch and alarms
- Extension cable harness with plug-and-play

### AIR INTAKE

- Turbocharged

### OTHER FEATURES

- Flywheel SAE 3
- Flexible engine mounting
- Damper pulley

### OPTIONAL SYSTEMS & ACCESSORIES

- Keel cooling adaptation
- Dry exhaust elbow
- Complete marine propulsion systems
- Marine transmission adaptation kits
- Throttle and shift controls
- Additional instrumentation, Flying bridge extension harness
- Rigid engine mounting
- Power take off
- Type approval

### RATINGS

- Up to 3000 annual operating hours
- Load factor up to 40%
- Full power for no ore than 1 hour out of 12 hours of operation. The remaining operation time must be at or below cruising speed

### TRANSMISSIONS

- Contact your Nanni representative for more details and availability about transmissions types and models range.

## PERFORMANCE CURVES

### POWER AT CRANKSHAFT

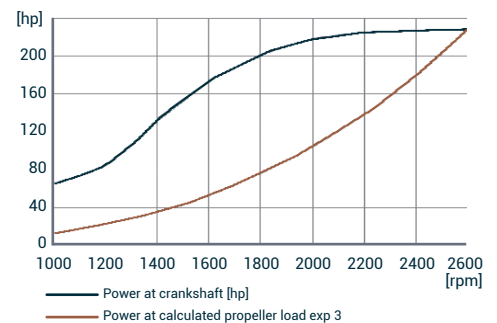

### TORQUE AT CRANKSHAFT

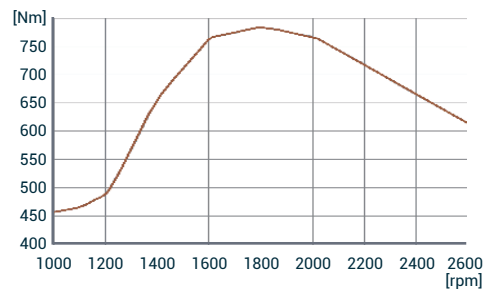

### FUEL CONSUMPTION

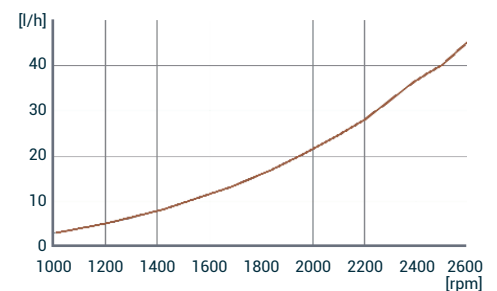

## DIMENSIONS

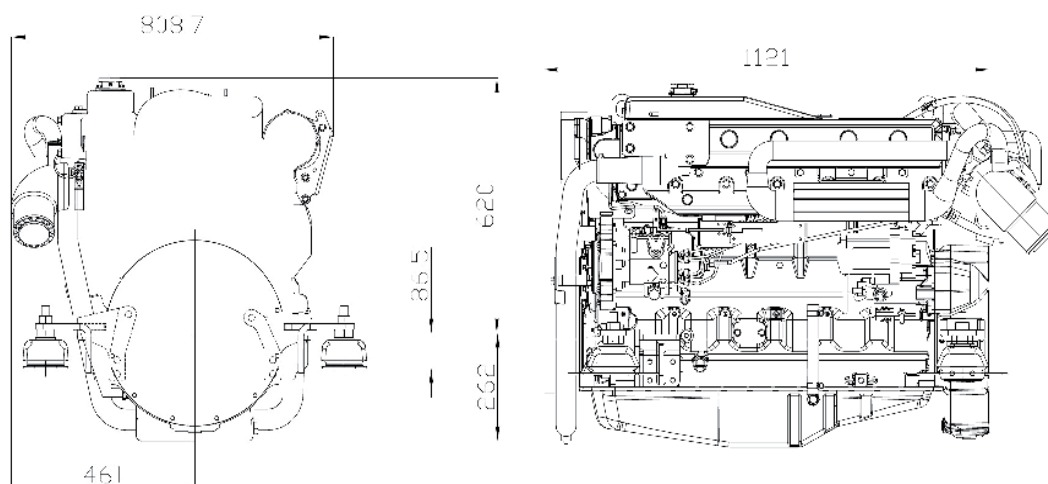

## NANNI INDUSTRIES S.A.S.

11, Avenue Mariotte - Zone Industrielle  
33260 La Teste - France  
Tel: +33 (0)5 56 22 30 60  
Fax: +33 (0)5 56 22 30 79

Technical data according to ISO 8665. This document is not contractual. Nanni reserves the right to modify any of the characteristics stated in this document without notice, in a constant effort to improve the quality of its products. Images and illustrations may show non standard equipments. All combination of equipment & accessory are not available.

DGBXXC01033