

N16.1000 CR3

SPECIFICATIONS



Power at crankshaft	736 kW [1000 hp]	Engine base	Scania
Displacement	16.4 l [1000.8 in ³]	Fuel system	Extra High Pressure Injection (XPI)
Configuration	8 cylinders in V	Air intake	Twin turbocharged with air-to-seawater after cooler
Operation type	4 stroke Diesel	Cooling	Closed cooling with heat exchanger and aftercooler
Bore & Stroke	130 x 154 mm [5.1 x 6.1 in]	Max mounting angle	12° Front up 12° Front down
Compression ratio	15.7 : 1	Alternator	24 Volt 100 Amp
Rated speed	2300 rpm	Rating	M5.L M6.S
Idling speed	600 rpm	Emission compliance	US Tier III RCD2
Peak torque	3665 Nm	Dry weight	1660 kg [3659.7 lbs]
Peak torque speed	1600 rpm		

N16.1000 CR3

736 kW [1000 hp] at 2300 rpm

TECHNICAL DESCRIPTION

ENGINE BLOCK

- Extra high pressure fuel injection system, XPI
- Twin Turbochargers
- Protection covers

FUEL SYSTEM

- Scania Engine Management System, EMS
- Fuel pre-filter with water separator
- Fuel filter

LUBRICATION SYSTEM

- Oil filter, full flow
- Centrifugal oil cleaner
- Oil cooler, integrated in block
- Oil draining with plug
- Shallow oil sump
- Oil dipstick

COOLING SYSTEM

- Sea water pump

ELECTRICAL SYSTEM & INSTRUMENTATION

- Starter, 2-pole 7.0 kW
- Alternator, 2-pole 24V / 100A

OTHER FEATURES

- Flywheel SAE 14"
- Silumin flywheel housing, SAE 1 flange
- Front-and-rear mounted engine brackets
- Closed crankcase ventilation
- Air cleaners
- Flexible engine mounts
- Damper

OPTIONAL SYSTEMS & ACCESSORIES

- Predisposition for SAE B hydraulic pump
- Axial front PTO
- Exhaust connections
- Cabin heater
- Rigid mounts
- Oil draining pump
- Oil level sensor
- Bilge pump

RATINGS

M5.L

- Up to 2000 hours per year
- Load factor up to 77%
- Full power for no more than 1 hour out of each 6 hours of operation.

M6.S

- Up to 500 hours per year
- Load factor up to 50%
- Full power for no more than 1 hour out of each 12 hours of operation.

TRANSMISSIONS

- Contact your Nanni representative for more details and availability about transmissions types and models range.

PERFORMANCE CURVES

POWER AT CRANKSHAFT

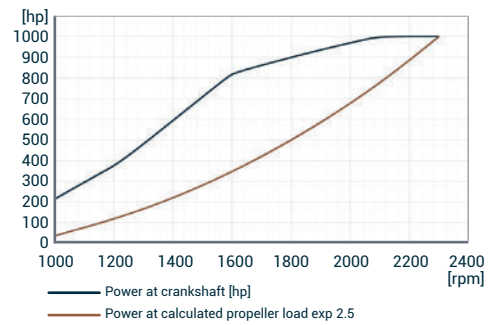

TORQUE AT CRANKSHAFT

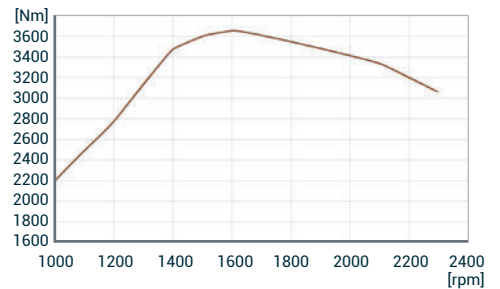

FUEL CONSUMPTION

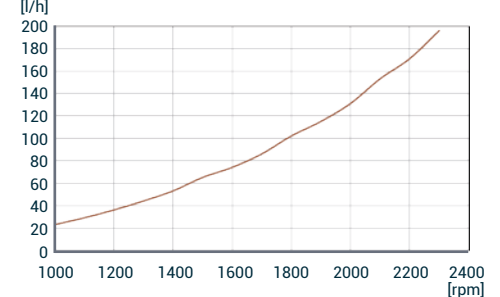

DIMENSIONS

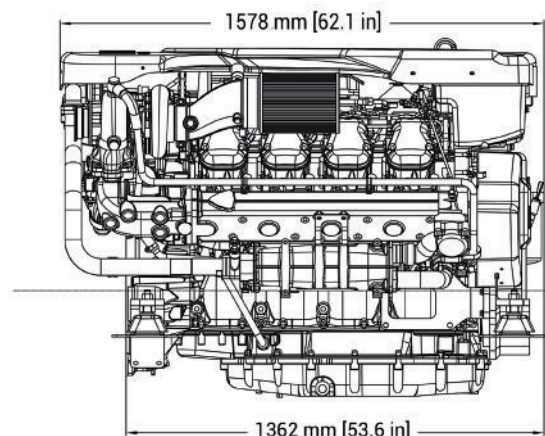
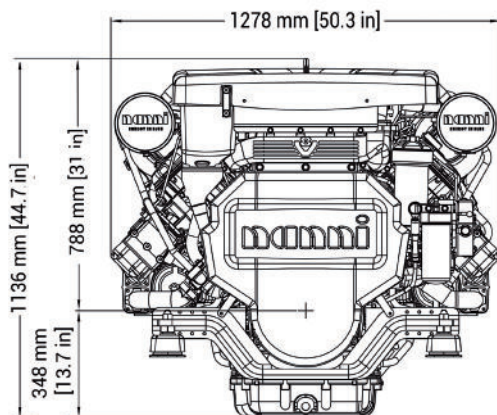

NANNI INDUSTRIES S.A.S.

11, Avenue Abbé Mariotte
33260 La Teste - France
Tel +33 (0)5 56 22 30 60
www.nannienergy.com

NANNI SRL

Via degli Olmetti, 44/A
00060 Formello - Roma - Italia
Tel +39 06 30 88 42 51
www.nannienergy.com

Technical data according to ISO 8665. This document is not contractual. Nanni reserves the right to modify any of the characteristics stated in this document without notice, in a constant effort to improve the quality of its products. Images and illustrations may show non standard equipments. All combination of equipment & accessory are not available.

DGBXXC01064B