

# N5.200 CR2

## SPECIFICATIONS

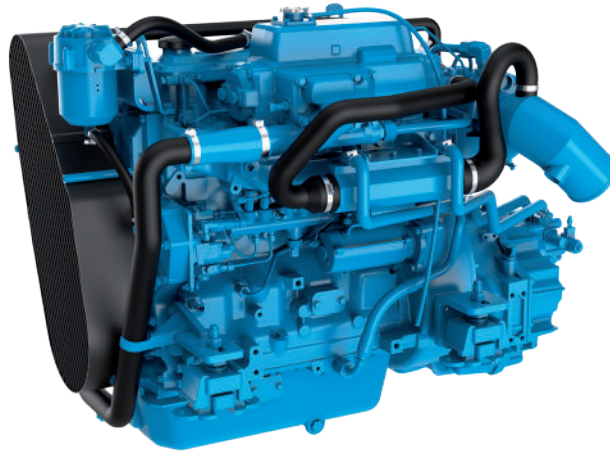

Power at crankshaft	149 kW [203 hp]	Engine base	John Deere
Displacement	4.5 l [275 in <sup>3</sup> ]	Fuel system	Direct injection Mechanical governor electronically controlled
Configuration	4 cylinders in line	Air intake	Turbocharged Air-to-seawater aftercooler
Operation type	4 strokes Diesel	Cooling	Closed cooling with heat exchanger
Bore & Stroke	106.4 x 127 mm [4.19 x 5 in]	Max mounting angle	0° Front down 12° Front up
Compression ratio	16.7 : 1	Alternator	24 Volt 50 Amp
Rated speed	2500 rpm	Rating	M3
Idling speed	600 rpm	Emission compliance	IMO Annex VI compliant EPA marine Tier 3 NRMM 97/68/EC RCD 2013/53/EU
Peak torque	695 Nm	Dry weight	578 kg [1274 lbs]
Peak torque speed	2000 rpm		

# N5.200 CR2

149 kW [203 hp] at 2500 rpm

## TECHNICAL DESCRIPTION

### ENGINE BLOCK

- Replaceable wet-type cylinder liners
- 4 valves per cylinder
- Watercooled exhaust manifold

### FUEL SYSTEM

- Common Rail fuel injection system
- Fuel heater
- Primary & secondary fuel filter

### LUBRICATION SYSTEM

- Replaceable full-flow oil filter
- Oil dipstick
- Oil cooler

### COOLING SYSTEM

- Closed cooling with heat exchanger
- Gear driven self-priming raw water pump
- Coolant circulating pump
- Water cooled exhaust elbow

### ELECTRICAL SYSTEM & INSTRUMENTATION

- 24V / 50A alternator
- 24V starter motor
- Complete instrumentation including key switch and alarms
- Extension cable harness with plug-and-play

### AIR INTAKE

- Turbocharged
- Air-to-seawater aftercooler

### OTHER FEATURES

- Flywheel SAE 3
- Flexible engine mounting
- Internal balancers

### OPTIONAL SYSTEMS & ACCESSORIES

- Keel cooling adaptation
- Dry exhaust elbow
- Complete marine propulsion systems
- Marine transmission adaptation kits
- Throttle and shift controls
- Additional instrumentation, Flying bridge extension harness
- Rigid engine mounting
- Power take off

### RATINGS

- Up to 4000 annual operating hours
- Load factor up to 50%
- Full power for no more than 4 hours out of 24 hours of operation. The remaining operation time must be at or below cruising speed

### TRANSMISSIONS

- Contact your Nanni representative for more details and availability about transmissions types and models range.

## PERFORMANCE CURVES

### POWER AT CRANKSHAFT

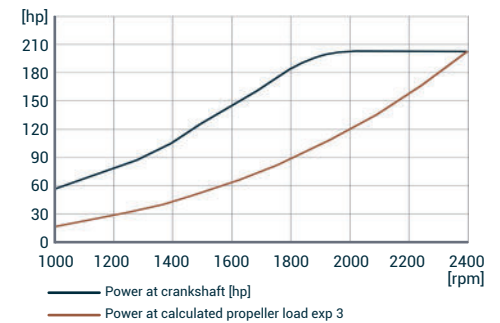

### TORQUE AT CRANKSHAFT

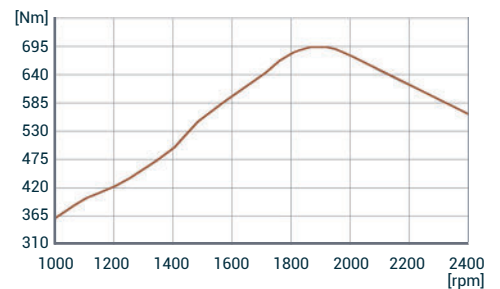

### FUEL CONSUMPTION

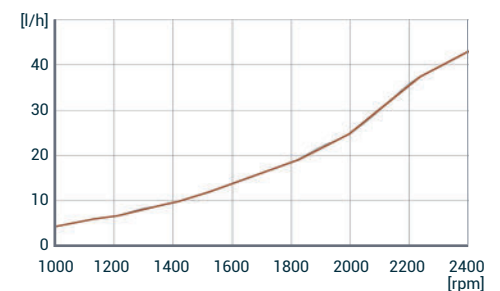

## DIMENSIONS

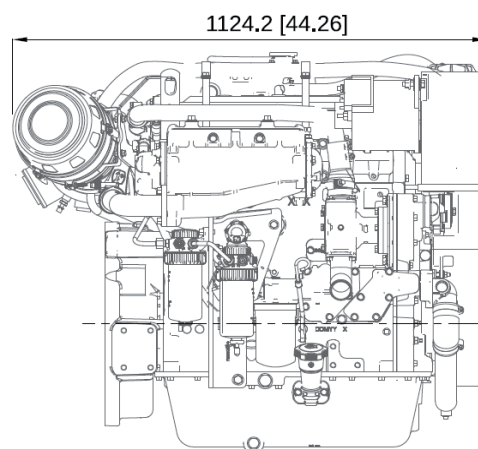
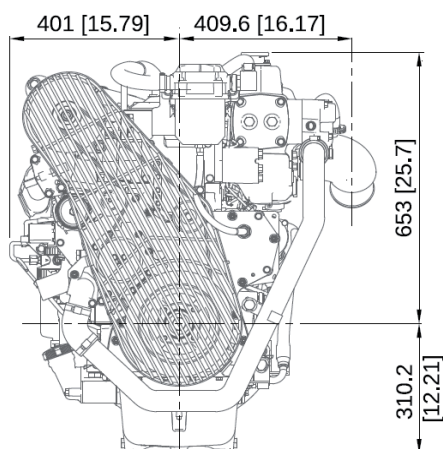

### NANNI INDUSTRIES S.A.S.

11, Avenue Abbé Mariotte  
33260 La Teste - France  
Tel +33 (0)5 56 22 30 60  
[www.nannienergy.com](http://www.nannienergy.com)

### NANNI SRL

Via degli Olmetti, 44/A  
00060 Formello - Roma - Italia  
Tel +39 06 30 88 42 51  
[www.nannienergy.com](http://www.nannienergy.com)

Technical data according to ISO 8665. This document is not contractual. Nanni reserves the right to modify any of the characteristics stated in this document without notice, in a constant effort to improve the quality of its products. Images and illustrations may show non standard equipments. All combination of equipment & accessory are not available.

DGBXXC01028B