

N6.360 CR2

SPECIFICATIONS

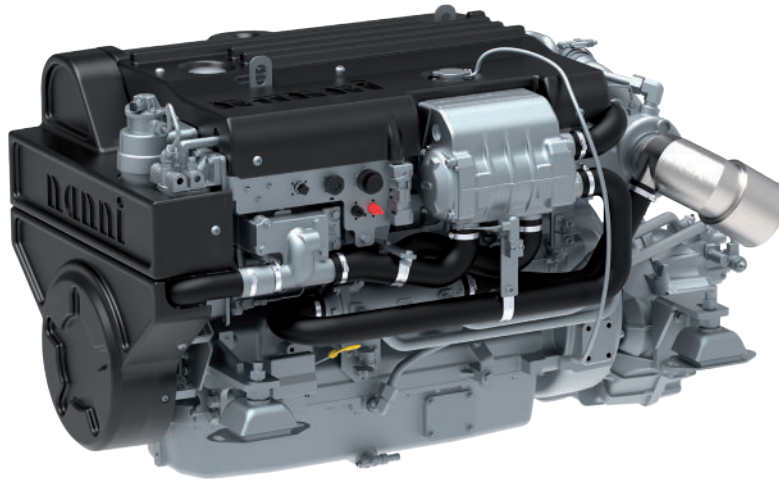

| | | | |
|---------------------|------------------------------|---------------------|---|
| Power at crankshaft | 265 kW [360 hp] | Engine base | John Deere |
| Displacement | 6.8 l [415 in ³] | Fuel system | Direct injection High pressure Common Rail Electronically controlled |
| Configuration | 6 cylinders in line | Air intake | Turbocharged Air-to-seawater aftercooler |
| Operation type | 4 strokes Diesel | Cooling | Closed cooling with heat exchanger |
| Bore & Stroke | 106.4 x 127 mm [4.19 x 5 in] | Max mounting angle | 0° Front down 12° Front up |
| Compression ratio | 16.3 : 1 | Alternator | 24 Volt 50 Amp |
| Rated speed | 2700 rpm | Rating | M4 |
| Idling speed | 600 rpm | Emission compliance | IMO Marpol Annex VI NRMM (97/68/EC) Tier 3 EPA marine Tier 3 RCD2 2013/53/EU |
| Peak torque | 1182 Nm | Dry weight | 735 kg [1620 lbs] |
| Peak torque speed | 2000 rpm | | |

N6.360 CR2

265 kW [360 hp] at 2700 rpm

TECHNICAL DESCRIPTION

ENGINE BLOCK

- Replaceable wet-type cylinder liners
- 4 Valves per cylinder
- Watercooled exhaust manifold

FUEL SYSTEM

- Primary & secondary fuel filter
- Fuel heater
- Common Rail fuel injection system

LUBRICATION SYSTEM

- Replaceable full-flow oil filter
- Oil dipstick
- Oil cooler

COOLING SYSTEM

- Closed cooling with heat exchanger
- Gear driven self-priming raw water pump
- Coolant circulating pump
- Water cooled exhaust elbow

ELECTRICAL SYSTEM & INSTRUMENTATION

- 24V / 50A alternator
- 24V starter motor
- Complete instrumentation including key switch and alarms
- Extension cable harness with plug-and-play

AIR INTAKE

- Turbocharged
- Air-to-seawater aftercooler

OTHER FEATURES

- Flywheel SAE 3
- Flexible engine mounting
- Damper pulley

OPTIONAL SYSTEMS & ACCESSORIES

- Keel cooling adaptation
- Dry exhaust elbow
- Complete marine propulsion systems
- Marine transmission adaptation kits
- Throttle and shift controls
- Additional instrumentation, Flying bridge extension harness
- Rigid engine mounting
- Power take off

RATINGS

- Up to 3000 annual operating hours
- Load factor up to 40%
- Full power for no more than 1 hour out of 12 hours of operation. The remaining operation time must be at or below cruising speed

TRANSMISSIONS

- Contact your Nanni representative for more details and availability about transmissions types and models range.

PERFORMANCE CURVES

POWER AT CRANKSHAFT

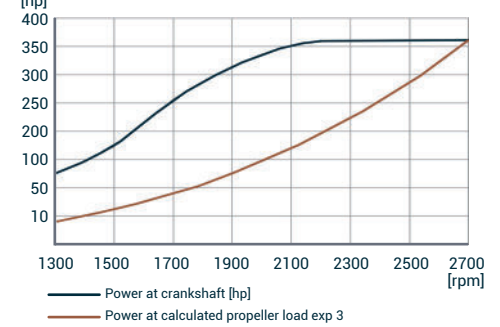

TORQUE AT CRANKSHAFT

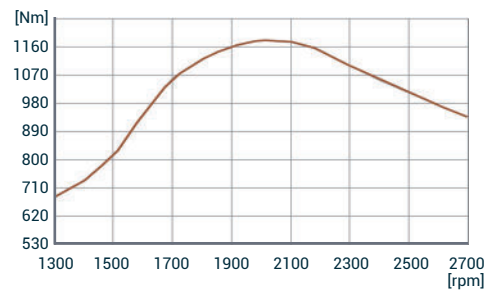

FUEL CONSUMPTION

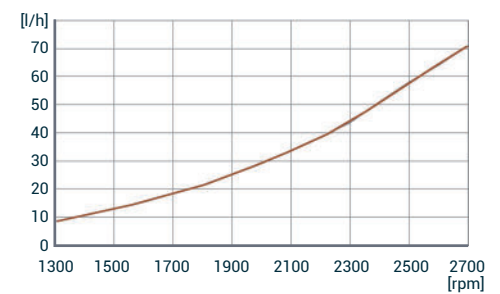

DIMENSIONS

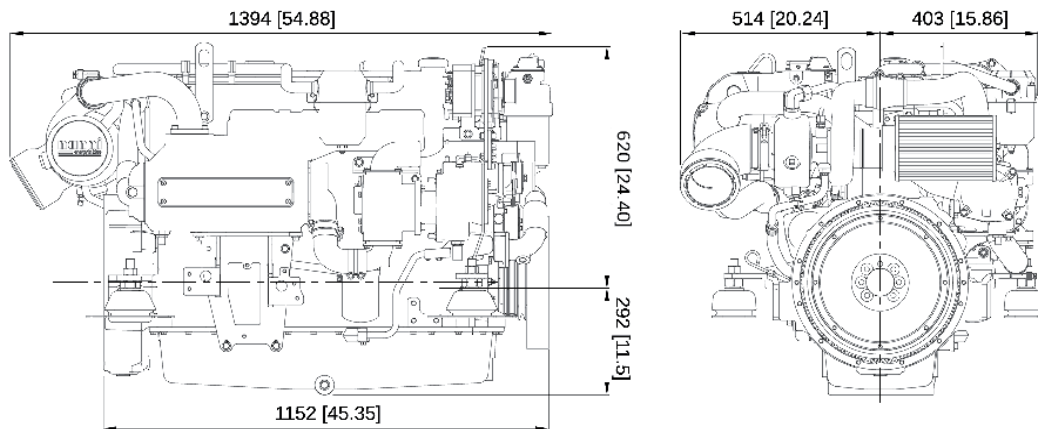

NANNI INDUSTRIES S.A.S.

11, Avenue Abbé Mariotte
33260 La Teste - France
Tel +33 (0)5 56 22 30 60
www.nannienergy.com

NANNI SRL

Via degli Olmetti, 44/A
00060 Formello - Roma - Italia
Tel +39 06 30 88 42 51
www.nannienergy.com

Technical data according to ISO 8665. This document is not contractual. Nanni reserves the right to modify any of the characteristics stated in this document without notice, in a constant effort to improve the quality of its products. Images and illustrations may show non standard equipments. All combination of equipment & accessory are not available.

DGBXXC01036B