

NANNI MARINE ENGINE

USER MANUAL

DGBXXT09018C

ENGINES

N13.700 CR3 HD

N13.700 CR3

N13.750 CR3

N13.800 CR3

N13.900 CR3

N13.930 CR3

The logo for Nanni, featuring the word "nanni" in a dark blue, lowercase, sans-serif font. The letters are stylized with rounded bottoms and a consistent thickness. The 'n' and 'i' have a white outline on their left and right sides respectively, while the 'a', 'm', and 'n' are solid dark blue.

NOTES

A series of horizontal dotted lines for writing notes.

S00 SUMMARY

Q00 TRACKED CHANGES	3	Oil grade denomination	24
TRACKED CHANGES	3	Oil grade labels	25
S00 SUMMARY	5	Oil analysis	25
S01 INTRODUCTION	7	FUELS	26
INTRODUCTION	7	Diesel fuel	26
ABOUT THIS MANUAL	8	Permitted sulphur content in diesel	26
Contents & updates	8	Temperature dependence of diesel	26
S02 SAFETY	9	Biodiesel (FAME)	27
SAFETY SIGNALS	10	Maintenance interval	27
A signal word	10	Storage of biodiesel	27
Engine - Genset safety Icons	11	HVO	27
SAFETY PRECAUTIONS	11	GTL	27
Hot exhaust precautions	11	Water in fuel	28
Work In ventilated area	11	Micro-organisms in fuel	28
Waste disposal	11	Inert impurities in fuel	28
Unwanted engine start	11	Long term diesel fuel storage	28
Safe maintenance practice	12	PRESERVATIVE PRODUCTS	28
Work In clean area	12	Preservative oil	28
Protective clothing	12	Preservative coolant	28
Service engines safely	12	Preservative fuel	28
Proper use of tools	12	DISPOSING OF WASTE FLUIDS	28
Support engines properly	12	S04 WARRANTY	29
Safe illuminated work area	12	ENGINE IDENTIFICATION	30
Proper lifting equipment	12	Original supplier engine plate	30
Noise protection	13	Engine approval	31
Genset output generated power	13	Engine responsibility	31
Guards requirements	13	Warranty	32
Staying clear of rotating drive lines	13	Proposition 65 state of California	32
Paint removal before heating	13	EPA warranty	33
High - pressure fuel system opening risk	13	S05 INSTRUMENTS	35
Avoid high - pressure fluids leaks	13	DASHBOARD	36
Safe cooling system service	14	DGBXXT09029 SI3 DIGITAL PANEL	36
Avoid heat near pressurized fluid lines	14	S06 COMPONENTS	37
Welding near electronic control unit (ECU)	14	ENGINE MAIN COMPONENTS	38
Static electricity risk	14	Engines views N13.CR3	39
Handle fuel safely - avoid fires	14	S07 START & RUNNING	41
Be prepared for emergencies	14	BEFORE STARTING	42
Handling batteries safely	15	Fuel system	42
Prevent battery explosions	15	Raw water system	42
Frost protection - winterization	15	Electrical system	42
Live with safety	16	Neutral safeguard	42
Prevent accidents	16	Check before starting	43
S03 FLUIDS	17	STARTING THE ENGINE	43
COOLANT	18	Cold weather operation	43
Water	18	Engine start	44
Antifreeze & corrosion protection	18	Ignition and cranking	44
Addition of antifreeze & corrosion inhibitor to water	18	Engine started	44
Risk of freezing	19	Starting with booster batteries	44
Hot climates	19	Engine reluctant to start	45
Topping up	19	Idling engine	45
Recommended coolant	20	Normal engine operation	45
Antifreeze & corrosion protection	21	Break in	46
Antifreeze & corrosion protection	22	Power take off	46
Checking the coolant level	23	Remote control	46
Checking the coolant's antifreeze & corrosion protection	23	RUNNING	47
ENGINE LUBRICANTS	24	Behaviour of the boat	47
		During operation	47
		Cruising speed	47

S00 SUMMARY

Manoeuvring	48	Electrolyte level check	86
Trolling valve	48	MISCELLANEOUS	87
AFTER RUNNING	49	Drive belt	87
Stopping the engine	49	Checking for leaks	88
After stopping the engine	49	Checking and adjusting the valve clearance	89
Anchoring	50	S09 STORAGE	91
Cold weather precautions	50	LONG TERM STORAGE	91
S08 MAINTENANCE	51	Long term storage procedure	91
ABOUT	52	Restarting the engine	92
GENERALITIES	52	Battery	92
MAINTENANCE INTERVALS	54	S10 TROUBLESHOOTING	93
MAINTENANCE INTERVALS	55		
TURBOCHARGER	56		
Turbo service	56		
CLEANING THE ENGINE	57		
EXHAUST SYSTEM	57		
AIR INTAKE	58		
Air cleaner	58		
Reading vacuum indicator	58		
Replace the air cleaner filter and safety cartridge	59		
Renewing an air filter with a non-renewable element	59		
FUEL SYSTEM	60		
Cleanliness requirements	60		
Checking fuel level	61		
Renewing the fuel filter	61		
Draining and renewing an engine-mounted water separating prefilter	62		
Draining and renewing the single water separating prefilter (option)	62		
Draining the commutative water separating prefilter (option)	64		
Renewing the commutative water separating prefilter (option)	65		
Bleeding the fuel system	66		
LUBRICATION SYSTEM	68		
Oil level - adding engine oil	68		
Changing the oil	69		
Cleaning centrifugal oil cleaner	70		
Operational testing of the centrifugal oil cleaner	72		
Replace the oil filter	73		
COOLING SYSTEM	74		
Coolant	74		
Checking coolant level	75		
Checking coolant antifreeze and corrosion protection	75		
Checking sacrificial anodes	76		
Checking sea water pump impeller	76		
Changing the coolant and cleaning the coolant system	77		
ELECTRICAL SYSTEM	84		
Wires and connectors	84		
Engine command connectors	84		
BATTERY	85		
Keep clean the battery	85		
Disconnect the starter cables	85		
Connect the cables	85		
Battery electrolyte level	85		

INTRODUCTION

Before starting the unit, make sure this manual is applicable to the model to be commissioned. Refer to the identification plate if you are not sure of the designation. If you do not have the correct manual, please contact your authorized Nanni dealer.

All information and specifications in this manual are based on the technical data available at the time of publication. Changes and updates may be made by Nanni without notice.

The illustrations serve as a general guide and may differ from the equipment in some details.

If any details of the equipment are not shown or described in this manual, or if you have any questions regarding the operation of any equipment, your authorized Nanni dealer will be pleased to inform you of the correct maintenance and operating procedures. Contact an authorized NANNI INDUSTRIES S.A.S. dealer for maintenance of your engine. A list of dealers is available on our website:

www.nannienergy.com

Read this manual carefully to learn how to properly operate and maintain your unit. Failure to do so could result in personal injury or property damage. This manual should be considered an integral part of the unit and should remain with the unit, even when it is sold.

The right and left sides are determined by standing at the drive end or flywheel (rear) of the motor and facing the front of the motor.

Record the motor serial numbers and option codes (if applicable). Your Nanni agent also needs these numbers when ordering parts. File the identification numbers in a secure place. Some engine accessories, such as air filters and some instruments, are optional. These accessories may be supplied by a third party. This manual only covers the engine and options available through the Nanni distribution network.

S01 INTRODUCTION

ABOUT THIS MANUAL

This manual contains important information, tips, suggestions and warnings. Please read it carefully and familiarize yourself with the engine before starting.

For your own safety and the longest life of the engine, follow the instructions and warnings contained in this manual and in any literature supplied with the boat. Ignoring them could damage the engine or cause injury to you or others.

Please make sure this manual is always in the boat. It must always be accessible to anyone using the engine, i.e., anyone renting, borrowing or buying the boat from you.

Any unauthorized modifications, or use outside its specified mechanical, electrical, or other operating limits may cause personal injury and/ or property damage, including damage to the engine. Any such unauthorized modifications: constitute «misuse» and/or «negligence» within the meaning of the product warranty there by excluding warranty coverage for any resulting damage and invalidate certifications or listings.

CONTENTS & UPDATES

All information and specifications contained in this manual are based on technical data applicable at the time of publication. Changes and updates may be made by Nanni without notice.

The illustrations are intended as a general guide, and may vary in some details.

If any details of the equipment are not shown or described in this manual, or if you have any questions about the operation of any equipment, your authorized NANNI dealer will be happy to inform you of the correct maintenance and operating procedures.

S02 SAFETY

S02 SAFETY	9
SAFETY SIGNALS	10
A signal word	10
Engine - Genset safety Icons	11
SAFETY PRECAUTIONS	11
Hot exhaust precautions	11
Work In ventilated area	11
Waste disposal	11
Unwanted engine start	11
Safe maintenance practice	12
Work In clean area	12
Protective clothing	12
Service engines safely	12
Proper use of tools	12
Support engines properly	12
Safe illuminated work area	12
Proper lifting equipment	12
Noise protection	13
Genset output generated power	13
Guards requirements	13
Staying clear of rotating drive lines	13
Paint removal before heating	13
High - pressure fuel system opening risk	13
Avoid high - pressure fluids leaks	13
Safe cooling system service	14
Avoid heat near pressurized fluid lines	14
Welding near electronic control unit (ECU)	14
Static electricity risk	14
Handle fuel safely - avoid fires	14
Be prepared for emergencies	14
Handling batteries safely	15
Prevent battery explosions	15
Frost protection - winterization	15
Live with safety	16
Prevent accidents	16

SAFETY SIGNALS

A SIGNAL WORD

DANGER, WARNING, or CAUTION

Is used in conjunction with the safety-alert symbol.

DANGER

Identifies the most serious hazard with lethal possible consequences.

WARNING

Identifies serious hazard with possible large injury consequences.

CAUTION

Identifies precautions to undertake which if not followed could lead to the above mentioned safety warnings. Damage to equipment could happen.

NOTICE

Is used for specific attention to sensitive actions on equipment. Other signals still applying.

IMPORTANT

Is a signal with a meaning of care to apply to equipment.

Safety Information

This symbol on the engine or in this manual is an alert to the potential for personal injury. Follow recommended precautions and safe operating practices.

Replacement Of Missing Or Damaged Safety Signs

Replace missing or damaged safety signs. There can be additional safety information contained on parts and components sourced from suppliers that is not reproduced in this Operator Manual.

Read Safety Instruction

Carefully read all safety messages in this manual and on your genset safety signs.

Keep safety signs in good condition. Be sure new equipment components and repair parts include the current safety signs.

Replacement safety signs are available from your dealer. There can be additional safety information contained on parts and components sourced from suppliers that is not reproduced in this Operator Manual.

Keep your equipment in proper working condition.



DANGER !



WARNING !



CAUTION !



IMPORTANT !



NOTE !

Please keep in mind that above safety labels have no degree of danger. Any irresponsible action could lead to a real danger situation.

Learn how to operate the equipment and how to use controls properly. Do not let anyone operate it without instruction.

Unauthorized modifications to the equipment may impair the function and/or safety and affect its life span.



If you do not understand any part of this document and need assistance, contact your NANNI representative

ENGINE - GENSET SAFETY ICONS

Some stickers are fixed directly on the engine. They are intended to help you to quickly identify the location of certain components and avoid possible hazards when working on the engine.

Ensure that these stickers are always visible and replace them if torn or washed up.



Refers to important informations and instructions to follow before handling the engine



Indicates possible electrical hazards



Indicates hot parts entailing substantial risks of burns



Indicates an area containing pressurised fluids



Indicates hazardous rotating parts



Stipulates that no flames or sparks should be created in the vicinity



Indicates where to check the coolant level



Indicates where to check the engine oil level



Indicates the coolant drain orifice



Indicates the oil drain orifice

SAFETY PRECAUTIONS

HOT EXHAUST PRECAUTIONS



Servicing machine or attachments with engine running can result in serious personal injury. Avoid exposure and skin contact with hot exhaust gases and components.

Exhaust parts and streams become very hot during operation. Exhaust gases and components reach temperatures hot enough to burn people, ignite, or melt common materials.

WORK IN VENTILATED AREA



Engine exhaust fumes can cause sickness or death. If it is necessary to run an engine in an enclosed area, remove the exhaust fumes from the area with an exhaust pipe extension.

If you do not have an exhaust pipe extension, open the doors and get outside air into the area.

WASTE DISPOSAL



Improperly disposing of waste can threaten the environment and ecology. Potentially harmful waste used in engines include such items as oil, fuel, coolant, fluids filters and batteries.

Use leak-proof containers when draining fluids; Do not pour waste into the sea, ground, down a drain, or into any other water source.

Contact your local environmental or recycling center, or your dealer for information on the proper way to recycle or dispose of waste.

UNWANTED ENGINE START



Avoid possible injury or death from engine runaway. Do not start engine by shorting across the starter motor solenoid terminals posts. Engine will start if normal circuitry is bypassed. Start engine from operator's seat.

S02 SAFETY

SAFE MAINTENANCE PRACTICE



Understand service procedures before doing work. Keep work area clean and dry. Never lubricate, service, or adjust engine while it is running. Keep hands, feet, hair and clothing away from moving parts.

Fix damage immediately. Replace worn or broken parts. Remove any build up of grease, oil, or debris. On self-propelled equipment, disconnect battery ground (-) before making adjustments on electrical systems or welding.

WORK IN CLEAN AREA



Clean work area and machine before starting a job. Make sure you have all necessary tools to do your job. Have the right parts on hand. Read all instructions thoroughly ; do not attempt short-cuts.

PROTECTIVE CLOTHING



Wear close fitting clothing and safety equipment appropriate to the job. Operating equipment safely requires the full attention of the operator. Do not wear radio or music headphones while operating the engine.

SERVICE ENGINES SAFELY



Tie long hair behind your head. Do not wear a neck tie, scarf, loose clothing, or necklace when you work near moving parts. If these items were to get caught, severe injury could result. Remove rings and other jewellery to prevent electrical shorts and entanglement in moving parts.

PROPER USE OF TOOLS



Use tools appropriate to the work. Makeshift tools and unfollowed procedures can create safety hazards. Do not use U.S mechanical tools on metric fasteners (i.e. a 1/2 inch wrench on a 13 mm nut).

Use power tools only to loosen threaded parts and fasteners. For loosening and tightening hardware, use the correct size tools. Avoid bodily injury caused by slipping wrenches. Use only service parts meeting manufacturer specifications.

SUPPORT ENGINES PROPERLY



Always lower the attachment or implement to the base before you work on an engine. If the work requires that the engine be lifted, provide secure system. If left in a raised position, hydraulically supported device can settle or leak down.

Do not support engines on any kind of props that may crumble. Do not work under an engine that is solely supported by a jack. Follow recommended procedures in this manual.

SAFE ILLUMINATED WORK AREA



Illuminate your work area adequately and safely. Use a portable safety light for working inside the engine room. Make sure the bulb is enclosed by a wire cage. The hot filament of an accidentally broken bulb can ignite spilled fuel or oil.

PROPER LIFTING EQUIPMENT



Lifting heavy components incorrectly can cause severe injury or equipment damage. Use expertise of staff holding relevant(s) legal capacity to operate heavy lifting equipment, with the know-how of using slings and chains.

S02 SAFETY

NOISE PROTECTION



Prolonged exposure to loud noise can cause impairment or loss of hearing. Wear a suitable hearing protective device such as earmuffs or earplugs to protect against objectionable or uncomfortable loud noises.

GENSET OUTPUT GENERATED POWER



Genset will deliver a sizeable amount of electrical power which can be lethal if not handled properly. Thus, any service, connection or repair on the alternator can only be done by a certified marine electrician.

GUARDS REQUIREMENTS



Rotating cooling system fans, belts, pulleys, and drives can cause serious injury. Keep all guards in place at all times during the engine operation. Wear close-fitting clothes.

Stop the engine and be sure that fans, belts, pulleys, and drives are stopped before making adjustments, connections, or cleaning near fans and their drive components.

STAYING CLEAR OF ROTATING DRIVE LINES



Entanglement in rotating driveline can cause serious injury or death. Keep all shields in place at all times. Make sure rotating shields turn freely.

Wear close-fitting clothing. Stop the engine and be sure that all rotating parts and drive lines are stopped before making adjustments, connections, or performing any type of service on engine or driven equipment.

PAINT REMOVAL BEFORE HEATING



Avoid potentially toxic fumes and dust. Hazardous fumes can be generated when paint is heated by welding, soldering, or in using a torch.

Paint removal:

- Remove paint a minimum of 100 mm (4 in) from area to be affected by heating. If paint cannot be removed, wear an approved respirator mask before heating or welding.
- If you sand or grind paint, avoid breathing the dust. Wear an approved respirator.
- If you use solvent or paint stripper, remove stripper with soap and water before welding. Remove solvent or paint stripper containers and other flammable material from area.
- Allow fumes to disperse for at least 15 minutes before welding or heating.
- Do not use a chlorinated solvent in areas where welding will take place.
- Do all work in an area that is well ventilated to carry toxic fumes and dust away.
- Dispose of paint and solvents properly.

HIGH - PRESSURE FUEL SYSTEM OPENING RISK



High-pressure fluid remaining in fuel lines can cause serious injury. Do not disconnect or attempt repair of fuel lines, sensors, or any other components between the high-pressure fuel pump and nozzles on engines with High Pressure Common Rail (HPCR) fuel system.

Only technicians familiar with this type of system can perform repairs. Consult your engine representative.

AVOID HIGH - PRESSURE FLUIDS LEAKS



Inspect hydraulic hoses periodically – at least once per year – for leakage, kinking, cuts, cracks, abrasion, blisters, corrosion, exposed wire braid or any other signs of wear or damage. Replace worn or damaged hose assemblies immediately with approved replacement parts.

Escaping fluid under pressure can penetrate the skin causing serious injury. Avoid the hazard by relieving pressure before disconnecting hydraulic or other lines. Tighten all connections before applying pressure. Search for leaks with a piece of cardboard.

SAFE COOLING SYSTEM SERVICE



Explosive release of fluids from pressurized cooling system can cause serious burns. Shut off engine. Only remove filler cap when cool enough to touch with bare hands. Slowly loosen cap to first stop to relieve pressure before removing completely.

AVOID HEAT NEAR PRESSURIZED FLUID LINES



Flammable spray can be generated by heating near pressurized fluid lines, resulting in severe burns to yourself and bystanders. Do not heat by welding, soldering, or using a torch near pressurized fluid lines or other flammable materials.

Pressurized lines can accidentally burst when heat goes beyond the immediate flame area.

Any fluid injected into the skin must be surgically removed within a few hours or gangrene may result. Doctors unfamiliar with this type of injury should reference a knowledgeable medical source.

WELDING NEAR ELECTRONIC CONTROL UNIT (ECU)



If welding is required around the engine, or in the engine room, ask first for a permission from the person in charge. Do not jump-start engine with arc welding equipment. Currents and voltages delivered are too high and may cause permanent damage. Direct welding onto the engine is forbidden.

1. Disconnect the negative (-) battery cable(s).
2. Disconnect the positive (+) battery cable(s).
3. Connect the positive and negative cables together. Do not attach to engine support frame.
4. Clear or move any wiring harness sections away from welding area.
5. Connect welder ground close to welding point and away from control units.
6. After welding, reverse Steps 1-5.

STATIC ELECTRICITY RISK



The removal of sulphur and other compounds in Ultra-Low Sulphur Diesel (ULSD) fuel decreases its conductivity and increases its ability to store a static charge. Refineries may have treated the fuel with a static dissipating additive.

However, there are many factors reducing the effectiveness of the additive over time. Static charges can build up in ULSD fuel while it is flowing through fuel delivery systems. Static electricity discharge in presence combustible vapours could result in a fire or explosion.

Therefore, it is important to ensure that the entire system used to refuel your engine (fuel supply tank, transfer pump, transfer hose, nozzle, and others) is properly grounded and bonded.

Consult your fuel or fuel system supplier to ensure that the delivery system is in compliance with fuelling standards for proper grounding and bonding practices.

HANDLE FUEL SAFELY - AVOID FIRES

Handle fuel with care: it is highly flammable. Do not refuel the engine while smoking or when near open flame or sparks. Always stop engine before refuelling.

Prevent fires by keeping engine room clean of accumulated trash, grease, and debris. Always clean up spilled fuel. Use only an approved fuel container for transporting flammable liquids.

Do not store fuel container where there is an open flame, spark, or pilot light such as within a water heater or other appliance.

BE PREPARED FOR EMERGENCIES



Be prepared if a fire starts. Keep a first aid kit and fire extinguisher handy. Keep emergency numbers for doctors, ambulance service, hospital, and fire department near your telephone.

HANDLING BATTERIES SAFELY



If not handled properly, batteries are a potential source of hazards. Excess of gases in batteries may explode. Keep sparks and flames away from batteries. Never use a cigarette lighter to observe electrolyte level. Use a flashlight to do it.

Use a flashlight to do it. Never check battery charge in shorting posts with a metal part. Use a voltmeter or hydrometer.

Always remove grounded (-) battery clamp first and replace grounded clamp last. Sulfuric acid in battery electrolyte is poisonous and strong enough to burn skin, eat holes in clothing, and cause blindness if splashed into eyes.

Avoid hazards and acid burns:



- Filling batteries in a well-ventilated area
- Wearing eye protection and rubber gloves
- Avoiding use of air pressure to clean batteries
- Avoiding breathing fumes when electrolyte is
- Avoiding spilling or dripping electrolyte
- Using correct battery booster or charger procedure.

If acid is spilled on skin or in eyes:



- Flush skin with water
- Apply baking soda or lime to help neutralize the acid
- Flush eyes with water for 15-30 minutes.
- Get medical attention immediately.

If acid is swallowed:



- Do not induce vomiting
- Drink large amounts of water or milk, but do not exceed 2 L (2 qt).
- Get medical attention immediately.

PREVENT BATTERY EXPLOSIONS



Keep sparks, lighted matches, and open flame away from the top of battery. Battery gas can explode. Never check battery charge by placing a metal object across the posts. Use a volt-meter or hydrometer. Do not charge a frozen battery: it may explode. Warm up battery to 16°C (60°F) before doing it.



Battery posts, terminals, and related accessories contain lead and lead compounds. Rinse hands after handling batteries.

FROST PROTECTION - WINTERIZATION

See Maintenance Section 08 - Raw Water System - Risk of icing conditions / Protection against frost.



When the engine has been set for winterization, place "DO NOT OPERATE" labels onto taps, valves, parts of equipment which have been turned off. Place a large and visible reminder on the wheelhouse dashboard.

S02 SAFETY

LIVE WITH SAFETY

Before returning engine to customer, make sure engine is functioning properly, especially the safety systems. Make sure that all guards and shields are in place.

PREVENT ACCIDENTS



When engine is OFF, always set the transmission lever to neutral position.

S03 FLUIDS

S03 FLUIDS	17
COOLANT	18
Water	18
Antifreeze & corrosion protection	18
Addition of antifreeze & corrosion inhibitor to water	18
Risk of freezing	19
Hot climates	19
Topping up	19
Recommended coolant	20
Antifreeze & corrosion protection	21
Antifreeze & corrosion protection	22
Checking the coolant level	23
Checking the coolant's antifreeze & corrosion protection	23
ENGINE LUBRICANTS	24
Oil grade denomination	24
Oil grade labels	25
Oil analysis	25
FUELS	26
Diesel fuel	26
Permitted sulphur content in diesel	26
Temperature dependence of diesel	26
Biodiesel (FAME)	27
Maintenance interval	27
Storage of biodiesel	27
HVO	27
GTL	27
Water in fuel	28
Micro-organisms in fuel	28
Inert impurities in fuel	28
Long term diesel fuel storage	28
PRESERVATIVE PRODUCTS	28
Preservative oil	28
Preservative coolant	28
Preservative fuel	28
DISPOSING OF WASTE FLUIDS	28

COOLANT



WARNING !

Products not fulfilling the demands in this section may lead to faults and damage occurring in the cooling system. This can lead to the invalidation of Nanni's warranty for faults and damage caused by the use of inappropriate coolant.



NOTE !

The coolant should be changed when the cooling system is cleaned: every 6,000 hours or at least every 5 years. See Changing the coolant & cleaning the cooling system.

The coolant recommended by Scania is a mixture of water with antifreeze (ethylene glycol) and corrosion inhibitor. The coolant has several characteristics which are important for the operation of the cooling system:

- Corrosion protection.
- Antifreeze.
- Increases the boiling point.

WATER

Use only pure fresh water that is free from particles, sludge and other impurities. If there is uncertainty about the quality of the water, Scania recommends use of Scania ready-mixed coolants. See the section Recommended Scania products.

ANTIFREEZE & CORROSION PROTECTION

The antifreeze and corrosion protection used in Scania engines should be antifreeze (ethylene glycol) and corrosion inhibitor.

Only Scania coolant or another product with functioning antifreeze and corrosion protection may be used in Scania engines. Products not fulfilling the demands in this section may lead to faults and damage occurring in the cooling system. This can lead to the invalidation of Scania's warranty for faults and damage caused by the use of inappropriate coolant.

ADDITION OF ANTIFREEZE & CORROSION INHIBITOR TO WATER

The coolant should contain 35-55% by volume antifreeze (ethylene glycol) and corrosion inhibitor. The percentage varies depending on the need for antifreeze.

A minimum of 35% by volume of Scania anti-freeze and corrosion inhibitor is needed to provide sufficient protection against corrosion.



NOTE !

Too high a dose of antifreeze and corrosion in-hibitor will increase the amount of sludge and blockages accumulating in the radiator. Too low a concentration can lead to corrosion of the cooling system and ice formation at low temperatures.

Measure the ethylene glycol content (antifreeze and corrosion protection) with a refractometer following the instructions in the Checking the coolant's antifreeze & corrosion protection section.

RISK OF FREEZING



IMPORTANT!

The engine should not be subjected to heavy loads when ice starts to build up in the cooling system.

As the coolant starts to freeze, the water in the coolant starts to crystallise and the percentage of ethylene glycol in the coolant therefore rises. If freezing produces a great increase in the amount of ice, circulation problems could arise. There is no risk of damage by freezing if the content of Scania antifreeze and corrosion inhibitor, or an equivalent mixture of a similar product, is at least 35% by volume.

Minimal ice formation in the coolant sometimes causes minor problems without any risk of damage. For example, the auxiliary heater may not work for up to 1 hour after the engine has been started.

The chart depicts coolant properties at different percents of antifreeze and corrosion inhibitor concentration by volume.

Curve A: Ice formation starts (ice slush)

Curve B: Damage by freezing

Range 1: Safe range

Range 2: Malfunctions may occur (ice slush)

Range 3: There is risk of damage by freezing

The following example shows coolant properties with 30 percent by volume of antifreeze and corrosion inhibitor:

- Ice slush starts to form at -16°C (3°F).
- At -30°C (-22°F), there is a risk of cooling system malfunction.
- There is no risk of damage by freezing with a minimum antifreeze and corrosion inhibitor content of 35 percent by volume.

Example:

If the temperature is -16°C (3°F), there is a risk of damage by freezing if the percentage of antifreeze and corrosion inhibitor is 20% by volume. At 30% antifreeze and corrosion protection by volume the coolant will not contain any ice.

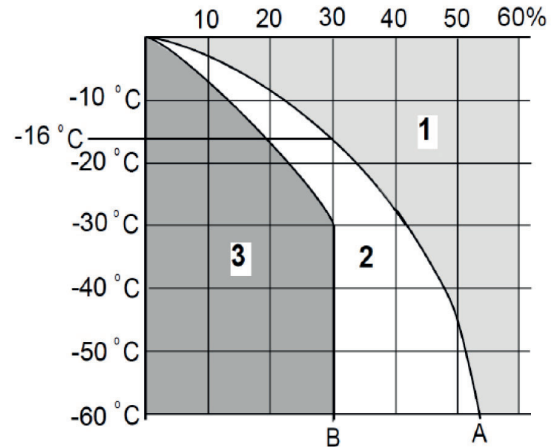

HOT CLIMATES

In order to retain the corrosion protection and the higher boiling point, it is essential to use coolant consisting of water mixed with antifreeze and corrosion inhibitor (ethylene glycol). This also applies in countries where the temperature never drops below 0°C (32°C).

The coolant should always contain 35-55% by volume of antifreeze and corrosion inhibitor so that the coolant properties ensure that the coolant works correctly.

TOPPING UP

Coolant must only be topped up with pre-mixed coolant. The pre-mixed coolant can either be concentrate mixed with clean freshwater or pre-mixed coolant from the factory. Use only pure fresh water that is free from particles, sludge and other impurities.



IMPORTANT!

Containers, which are used for mixing coolant, must be intended for the purpose and free from any dirt or contaminants. When the containers not in use they must be kept closed to avoid collecting dirt and dust.



NOTE!

Within the coolant change interval, coolant may only be reused if it has been cleaned of dirt, sludge and particles. If the coolant is contaminated with oil or fuel, it must not be reused.

RECOMMENDED COOLANT

Scania Ready-Mix 50/50

Scania Ready-Mix 50/50 is a ready to use coolant containing 50 % antifreeze (ethylene glycol) and corrosion protection and 50 % water. It should be used in cold countries where there is a risk of freezing in the cooling system.

Part #	Volume litres	Volume U.S Gallons
1 921 955	5	1.3
1 921 956	20	5.3
1 921 957	210	55
1 896 695	1000	264

Scania Ready-Mix 35/65

Scania Ready Mix 35/65 is a ready-mixed coolant containing 35% antifreeze (ethylene glycol) and corrosion protection and 65% water. It should be used in warm countries where there is no risk of freezing in the cooling system.

Part #	Volume litres	Volume U.S Gallons
2 186 291	5	1.3
2 186 292	20	5.3
2 186 293	210	55
2 186 294	1000	264

Scania Concentrate

Scania also produces coolant with antifreeze and corrosion inhibitor in the form of a concentrate.

Part #	Volume litres	Volume U.S Gallons
1 894 323	5	1.3
1 894 324	20	5.3
1 894 325	210	55
1 894 326	1000	264

ANTIFREEZE & CORROSION PROTECTION

TABLE in LITRES & °C

35% by volume of antifreeze provides sufficient protection against corrosion.

Example:

- The total volume of the cooling system is 40 litres.
- The measured concentration of ethylene glycol is 35% by volume (freezing point -21°C). According to the table, there are 14 litres of ethylene glycol in the cooling system.
- The required concentration of ethylene glycol is 45% by volume (freezing point -30°C). According to the table, 18 litres of ethylene glycol are required in the cooling system.
- Since there are already 14 litres in the cooling system, 4 litres of ethylene glycol must be added to the cooling system (18 - 14 = 4 litres).

	ADEQUATE PROTECTION AGAINST CORROSION					
VOLUME OF ETHYLENE GLYCOL (%)	35	40	45	50	60	COOLING SYSTEM VOLUME (LITRES)
ICE SLUSH FORMS (°C)	-21	-24	-30	-38	-50	
VOLUME OF ETHYLENE GLYCOL (LITRES)	11	12	14	15	18	30
	14	16	18	20	24	40
	18	20	23	25	30	50
	21	24	27	30	36	60
	25	28	32	35	42	70
	28	32	36	40	48	80
	32	36	41	45	54	90
	35	40	45	50	60	100
	39	44	50	55	66	110
	42	48	54	60	72	120
	46	52	59	65	78	130
	49	56	63	70	84	140
	53	60	68	75	90	150
	56	64	72	80	96	160
	60	68	77	85	102	170
	63	72	81	90	108	180
67	76	86	95	114	190	
70	80	90	100	120	200	

ANTIFREEZE & CORROSION PROTECTION

TABLE in U.S GALLONS & °F

35% by volume of antifreeze provides sufficient protection against corrosion.

Example:

- The total volume of the cooling system is 10.6 U.S gallons.
- The measured concentration of ethylene glycol is 35% by volume (freezing point -6 °F). According to the table there are 3.7 U.S gallons of ethylene glycol in the cooling system.
- The required concentration of ethylene glycol is 45% by volume (freezing point -22°F). According to the table, 4.8 U.S gallons of ethylene glycol are required in the cooling system.
- Since the cooling system already contains 3.7 U.S gallons, fill another 1.1 U.S gallons of ethylene glycol in the cooling system (4.8 - 3.7 = 1.1 U.S gallons).

		ADEQUATE PROTECTION AGAINST CORROSION					COOLING SYSTEM VOLUME (U.S GALLONS)
VOLUME OF ETHYLENE GLYCOL (%)	ICE SLUSH FORMS (°F)	35	40	45	50	60	
VOLUME OF ETHYLENE GLYCOL (U.S GALLONS)	2.9	3.2	3.7	4	4.8	7.9	
	3.7	4.2	4.8	5.3	6.3	10.6	
	4.8	5.3	6.1	6.6	7.9	13.2	
	5.5	6.3	7.1	7.9	9.5	15.9	
	6.6	7.4	8.5	9.2	11.1	18.5	
	7.4	8.5	9.5	10.6	12.7	21.1	
	8.5	9.5	10.8	11.9	14.3	23.8	
	9.2	10.6	11.9	13.2	15.9	26.4	
	10.3	11.6	13.2	14.5	17.4	29.1	
	11.1	12.7	14.3	15.9	19	31.7	
	12.2	13.7	15.6	17.2	20.6	34.3	
	12.9	14.8	16.6	18.5	22.2	37	
	14	15.9	18	19.8	23.8	39.6	
	14.8	16.9	19	21.1	25.4	42.3	
	15.9	18	20.3	22.5	26.9	44.9	
16.6	19	21.4	23.8	28.5	47.6		
17.7	20.1	22.7	25.1	30.1	50.2		
18.5	21.1	23.8	26.4	31.7	52.8		

CHECKING THE COOLANT LEVEL



WARNING !

Do not open the coolant filler cap in the expansion tank if the engine is hot. Hot coolant and steam may spray out and cause burns. If the cap has to be opened do it slowly to release the pressure before removing the cap. Use protective gloves as coolant can cause irritation if it comes in contact with the skin.



IMPORTANT !

It is not permissible to top up large amounts of coolant via the expansion tank. Filling via the expansion tank leads to air locks in the cooling system which can lead to e.g. cavitation damage to the coolant pump shaft seal. If a large amount of coolant needs to be added, follow the instructions in the section **Filling coolant**.

Only pour pre-mixed coolant into the cooling system.

The following instructions apply to Scania expansion tanks. For other types of expansion tanks, follow the manufacturer's instructions.

1. Check the coolant level through the sight glass on the expansion tank.
2. Top up with coolant as necessary.

CHECKING THE COOLANT'S ANTIFREEZE & CORROSION PROTECTION

Specific tool

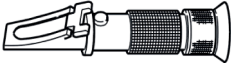
Description	Illustration
Refractometer	
	



WARNING !

Avoid skin contact with coolant as this may cause irritation to the skin. Wear protective goggles and gloves when handling coolant.



IMPORTANT !

Use only pure fresh water that is free from particles, sludge and other impurities.

1. Pour a small amount of coolant into a container and check that the coolant is pure and clear.
2. Change the coolant if it is contaminated or cloudy.
3. Measure the antifreeze and corrosion inhibitor content with the refractometer.

The following rules apply to ethylene glycol-based coolant:

- The antifreeze and corrosion inhibitor content must be minimum 35 percent by volume for corrosion protection to be sufficient.
- An antifreeze and corrosion inhibitor content greater than 55 percent by volume impairs the ability to protect against frost.
- If ice forms in the coolant, there are disruptions initially, but there is no immediate risk of damage. The engine should not be subjected to heavy loads when ice starts to form.

ENGINE LUBRICANTS

OIL GRADE DENOMINATION

LDF branded oil stands for the Scania **Long Drain Field** test standard. Scania LDF oils have been carefully selected after extensive testing. The approval is only granted to the highest quality engine oils available on the market.

Recommended engine oil

- Scania Oil LDF-3
- Scania Oil LDF-2
- Scania oil LDF
- Scania Oil E7.

The engine oil must fulfil the following quality requirements:

- ACEA E5/API CI-4.
- ACEA E7/API CI-4 +.
- For engines not run on low-sulphur fuel, the TBN (Total Base Number) should be at least 12 (ASTM D2896).
- Oils with a low ash content (ACEA E9/API CJ4) are not recommended.

Check with your oil supplier that the oil meets these requirements.

If the engine is used in areas of the world where engine oil with ACEA or API classification is not available, the oil grade must be measured in actual operation. In this case contact the nearest Nanni workshop.

For operation at extremely low outdoor temperatures: Consult your nearest Nanni representative on how to avoid starting difficulties.

Viscosity class	Outdoor temperatures in °C	
SAE 20W-30	-15°C	+30°C
SAE 30	-10°C	+30°C
SAE 40	-5°C	+45°C
SAE 50	0°C	+45°C
SAE 5W-30	<-40°C	+30°C
SAE 10W-30	-25°C	+30°C
SAE15W-40	-20°C	+45°C

Viscosity class	Outdoor temperatures in °F	
SAE 20W-30	5°F	86°F
SAE 30	14°F	86°F
SAE 40	23°F	113°F
SAE 50	32°F	113°F
SAE 5W-30	<-40°F	86°F
SAE 10W-30	-13°F	86°F
SAE 15W-40	-4°F	113°F

OIL GRADE LABELS

When changing oil it is important to use the correct engine oil grade. The oil filler should therefore be clearly marked with a label for the filled oil grade. However, there are only labels for oils with Scania LDF approval and oil grade ACEA E7.

Stick on a new label if the oil type or oil grade is changed in favour of any of the oil types above. Replace the label if it is missing.

If the oil grades below are used, you can order oil filler labels from your Nanni representative.

Oil grade	Colour	Part #
Scania LDF-3	Red	2 296 066
Scania LDF-2	Blue	2 296 064
Scania LDF	Grey	2 296 071
ACEA E7	White	2 296 065
Scania Low Ash	Green	2 296 067
Scania Bioethanol	Black	2 296 068
Scania BEO-2	Orange	2 296 070
ACEA E9	-	2 296 069

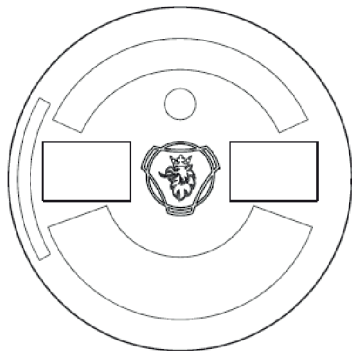

Oil filter label

OIL ANALYSIS

To be able to extend the oil change intervals using an oil analysis, Scania LDF-3 and LDF-2 oils must be used. Certain laboratories offer engine oil analysis.

The following conditions must remain fulfilled when the oil is changed:

- Viscosity at 100°C (212°F): max. ±20% of original value of the fresh oil.
- TBN (in accordance with ASTM D4739): > 3.5.
- TBN (in accordance with ASTM D4739): > TAN (in accordance with ASTM D664).
- Soot (according to DIN 51452): <3%.
- Fuel in the oil: <5%.

Such analysis measures the oil's TBN (Total Base Number), TAN (Total Acid Number), fuel dilution, water content, viscosity and the quantity of particles and soot in the oil.

The result of a series of analyses is used as the basis for establishing a suitable oil change interval.

If the conditions are changed, a new oil analysis programme must be carried out to establish new oil change intervals. Work out the new oil change interval for the engine in conjunction with the workshop.



REQUIREMENT !

Only Scania LDF oils may be used in conjunction with oil analysis and a possible extended oil change interval. Depending on the market, the warranty conditions may also change if the oil change intervals differ from the recommended Scania timetable.

FUELS



DANGER!

Fuels and some fluids on board ships are easily flammable. Handle fuels with care and respect all safety rules. Do not refuel the tank while the engine is running. Do not smoke during the filling process or in the engine compartment. Ventilate the engine compartment before starting. Wear protective gloves and eye protective glasses. Avoid synthetic clothing which can melt when ignited. Always keep a fire extinguisher nearby.

DIESEL FUEL

Properties

The quality of the diesel is very important for the operation and service life of the engine and the fuel system, and also for the engine performance.



REQUIREMENT!

The diesel fuel should comply with the requirements of European standard EN590.

However, larger tolerances of certain properties are accepted. Please see the table below:

Properties	Requirements
Viscosity at 40°C (104°F)	1.4-4.5 cST
Density at 15°C (59°F)	0.79-0.87 kg/dm ³
Ignitability (CET rating)	minimum 49
Lowest flashpoint	56°C (132°F)
Particulate contamination level	Classification 22/20/17 according to ISO 4406

PERMITTED SULPHUR CONTENT IN DIESEL



IMPORTANT!

The operator is responsible for using the correct type of diesel to ensure that local laws are complied with.

Sulphur content	Remark
0-2000 ppm (<0.2 %)	Normal oil change interval of up to 500 hours
2000-4000 ppm (0.2-0.4 %)	The oil change interval must be halved to a maximum of 250 hours.
4000 ppm (0.4 %)	Max. permitted sulphur content. If diesel with too high a sulphur content is used, this causes engine damage.

TEMPERATURE DEPENDENCE OF DIESEL



IMPORTANT!

Mixing kerosene or other paraffins with the diesel fuel is prohibited. The injectors may be damaged.

It is not permissible to mix petrol with diesel fuel. In the long term, petrol can cause wear in the injectors and engine.

At temperatures lower than those specified for the diesel, paraffin wax may precipitate from the diesel fuel and block filters and pipes. The engine can then lose power or stop.

The diesel fuel is adapted for use in the specific climate of each country. If an engine is to be operated in a temperature zone with a temperature lower than normal, first identify the temperature properties of that particular diesel fuel.

BIODIESEL (FAME)

Use of biodiesel



IMPORTANT !

For engines with SCR systems, a maximum of 10% mixture of biodiesel should be used.

Scania uses the term biodiesel to refer to a renewable diesel made from greases or oils and methanol. The biodiesel should conform to the requirements of European standard EN 14214 or Brazilian standard ANP-45. For biodiesel in accordance with EN 14214 or ANP-45, the generic term FAME is frequently used.

Normal diesel in accordance with EN 590 can contain up to 7% biodiesel from the diesel supplier. There are grades of diesel that comply with EN 590 but contain a higher mixture of biodiesel.

Scania approves up to a 10% mixture of biodiesel for all engines.

For PDE engines, Scania approves the use of up to 100% biodiesel in accordance with EN 14214 or ANP-45. However, this does not apply to engines with an SCR system, for which only a 10% mixture is permitted.

MAINTENANCE INTERVAL



IMPORTANT !

Make sure that maintenance intervals are different when operating on diesel or biodiesel.

With a greater mixture of biodiesel than 10%, the renewal intervals for the following are halved:

- Fuel filter.
- Oil filter.
- Engine oil.

The viscosity grade of the engine oil should be xW-40. xW-30 grade oils are unsuitable due to the fuel dilution effect.

Check the engine oil level regularly. If the oil level exceeds the maximum level, the oil must be changed. Check the cause if the oil level exceeds the maximum level and contact your nearest Nanni representative if you suspect a fault, or in case of doubt.

STORAGE OF BIODIESEL



IMPORTANT !

Biodiesel must not be stored for more than 6 months.

Biodiesel has a maximum storage life of 6 months from the date of production to the expiry date. The fuel is affected by light, temperature, water, etc. during storage, which affects the fuel characteristics and durability.

Biodiesel also has lower stability against oxidation than diesel. This can result in a thickening of the fuel and blocking of parts of the fuel system, e.g. the fuel filter. Bacterial growth can occur when fuel is stored in tanks under unfavourable conditions. Avoid storage in barrels or auxiliary tanks, except when fuel turnover rates are high. Check tank cleanliness whenever refuelling takes place.

If the engine has been refuelled with biodiesel, and is stationary for a long period, condensation water can form in the fuel tank resulting in bacterial growth.

See also the [Preservative fuel paragraph in the following pages.](#)

HVO

HVO is a synthetic diesel which is manufactured through the hydrogenation of plants and animal fats. To the user, HVO is reminiscent of diesel in accordance with EN590, apart from HVO having a somewhat lower density. Scania approves the use of up to 100% HVO for all engines in accordance with the European standard EN 15940.

GTL

GTL is a synthetic fuel that is often refined from natural gas. To the user, GTL is reminiscent of diesel in accordance with EN590, apart from GTL having a somewhat lower density and less odour. Scania approves the use of up to 100% GTL in accordance with the European standard EN 15940.

WATER IN FUEL

Water is a non-flammable and incompressible liquid. For this reason, its presence is particularly harmful to the operation of the engine and to the entire fuel injection system. Water easily enters the tank by simple condensation and especially when it is left or partially empty. Fill up the fuel tank before storage/winter storage. Check the water-diesel separator regularly and clean it as required. Anticipate the replacement of the fuel filter. If a large quantity of water is present in the tank, drain it and flush the entire fuel and injection system with clean diesel fuel. Water in the diesel fuel can cause irreparable damages to the engine and are not covered by any warranty from Nanni Industries.

MICRO-ORGANISMS IN FUEL

The presence of water in the tank automatically leads micro-organisms and bacteria to grow and will mix with the fuel. These micro-organisms grow rapidly with a favourable temperature. Depending on their size, they can pass through filters and penetrate in the fuel injection system and cause a total engine failure which is not covered by Nanni Industries warranty. In the event of fuel contamination, contact the nearest Nanni agent who may, if necessary, use an approved disinfectant.

INERT IMPURITIES IN FUEL

Others impurities than micro-organisms and bacteria do exist : they are rust debris falling out from the internal walls of the metal tanks.

Some types of fibreglass tanks are also subject to osmosis over time and tiny particles may come off internal walls and circulate in the diesel fuel. These impurities can pass through the filters and creep into the injection system and cause a total failure of the engine which is not covered by Nanni Industries warranty.

LONG TERM DIESEL FUEL STORAGE

Long-term storage of diesel fuel, where the diesel comes into contact with water, may lead to the growth of micro-organisms (bacteria and fungus).

PRESERVATIVE PRODUCTS

PRESERVATIVE OIL

Always use an engine oil meeting the requirements in the Oil grade section.

Beware that moist in oil opened container drums has ability to deplete oil characteristics.

PRESERVATIVE COOLANT

Use coolant containing 50% by volume of glycol. Example: BASF MPG Glysacorr P113 and Valvoline Zerex P113 FP.



WARNING !

Ethylene glycol can be fatal if ingested and can cause skin irritation and eye damage.

PRESERVATIVE FUEL

Preservative fuel must not contain biodiesel. Even small amounts of 5-10% biodiesel can have adverse effects on the engine when in longterm storage.

DISPOSING OF WASTE FLUIDS

Prior to contemplate any draining, make sure that all adequate gear such as: funnel(s), hose(s), suitable container(s) and so on, are at hand. Use leakproof containers when draining fluids. Do not use food or beverage containers that may mislead someone into drinking from them. Wear gloves and eye protection glasses. Follow all safety rules. Wait for engine to cool down. Do not let waste to drip on the ground, down a city drain, or into any water source. Improperly disposing of engine coolants, oils, or other chemical fluids is a threat against environment and is an offence in many countries.



Inquire on the proper way to recycle or dispose of waste from your local environmental or recycling center, or from your Nanni engine representative or service dealer.

S04 WARRANTY

S04 WARRANTY	29
ENGINE IDENTIFICATION	30
Original supplier engine plate	30
Engine approval	31
Engine responsibility	31
Warranty	32
Damage caused	32
Proposition 65 state of California	32
EPA warranty	33
Emission control system(s) laws	33
European Union (EU) declaration of emissions and conformity	33

S04 WARRANTY

ENGINE IDENTIFICATION

Both the engine and the alternator have an identification plate showing important informations.

Keep these plates accessible and in good condition. Record and keep serial number and designation. These numbers should always be quoted when ordering service and replacement parts. Depending of type of engine, identification plate are as follows:



Or:

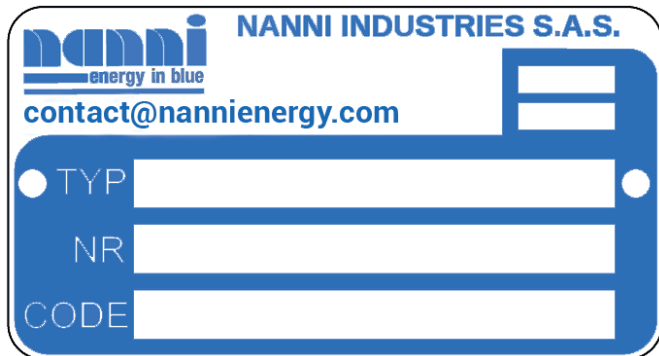

TYP	Indicates the commercial designation of the engine.
NR	Indicates the engine serial number.
CODE	Lists various specifications of the engine.



NOTE !

ID plates may differ in appearance from models shown above without any change in equipment itself.

Example:

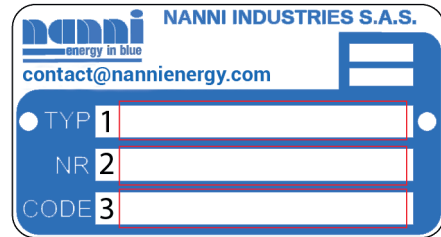

- 1 : Type of engine
- 2 : Nanni engine serial number
- 3 : Engine code

ORIGINAL SUPPLIER ENGINE PLATE

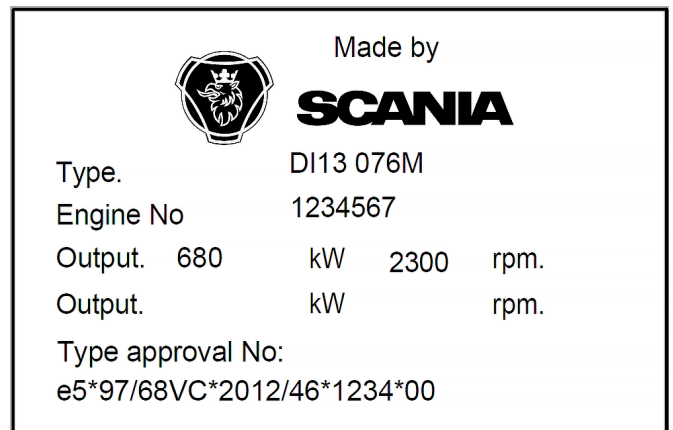

Example : **DI13 076M**

- DI** : Supercharged diesel engine with watercooled charge air cooler.
- 13** : Displacement in whole dm³.
- 076** : Performance and certification code. The code indicates, together with the application code, the normal gross engine output.
- M** : Code for application. M means for marine use.

S04 WARRANTY

ENGINE APPROVAL

The engine type can be exhaust emission certified. It means that Nanni guarantees that all engines of the same type that are manufactured are approved and certified by the authorities in accordance with different exhaust emissions standards.

For the engine to be in accordance with this standards, special requirements for maintenance and service are to be followed:

- Only Nanni replacement parts must be used.
- Maintenance intervals must be observed.
- The engine must not be modified in any way except with accessories and service kits approved by Nanni Industries S.A.S. France.
- Service of the fuel system must always be carried out by an authorized Nanni workshop.
- No modifications to the air intake and exhaust system may be undertaken.
- Seals may only be broken by authorized personnel.
- The operation instructions stated in the relevant manuals should be followed by the user.

Nanni's responsibility for the engine specification being in accordance with the certification will be void if one or several of these conditions are breached.

ENGINE RESPONSIBILITY

Nanni designs its engines to have minimum environmental impact. This objective, however, can only be achieved with your full cooperation.

Our operating and maintenance instructions are to help you to protect your engine and adopt environmentally responsible behaviour.

Ensure you only use the fuels and oils recommended. Using another type of fuel or oil could cause major malfunctions, a higher fuel consumption, a reduced engine service life, and a greater discharge of exhaust gases.

When draining the oil and changing the oil or fuel filter, dispose of the waste in an appropriate container. These fluids cause major damage to flora and fauna if discharged into nature. Use an absorption kit in the event of accidental discharge of oil or fuel into the water.

S04 WARRANTY

WARRANTY

This manual is supplemented by a Warranty Information Booklet. We recommend that you read this publication thoroughly.

Pay special attention to the applicable duty cycle and to the resulting limitations. Failure to comply with the warranty conditions will void the Warranty.

The validity of the Warranty is also dependent on proper installation and maintenance operation being carried out by an authorized Nanni representative.



NOTE !

Late or improper maintenance or use of spare parts other than NANNI original spare parts will invalidate NANNI's responsibility for the engine accordance with approval and will void the Warranty.

Modifications to the engine's settings, as well as any other technical modification (accessories, spare parts, additional equipment, etc) **ARE FORBIDDEN WITHOUT WRITTEN AUTHORIZATION FROM NANNI INDUSTRIES S.A.S.**

Any modification will void the Warranty.

Damage caused

Damage caused by failure to follow operation instructions or incorrect operation is also not covered by the warranty.

PROPOSITION 65 STATE OF CALIFORNIA



WARNING!

Diesel engine exhaust and some of its constituents are known to the state of California to cause cancer, birth defects, and other reproductive harm.

Battery posts and terminals, related devices do contain lead or Lead compounds, chemicals known to State of California to cause cancer, birth defects or other reproductive harm. Thoroughly wash your hands after handling any of the above components

S04 WARRANTY

EPA WARRANTY

EPA and CARB warranties only apply to new engines having the certification label affixed to the engine and sold as stated above in the geographic areas.

The presence of an EU number signifies that the engine has been certified with the European Union countries per Directive 97/68/EC. The EPA and/or CARB emissions warranties do not apply to the EU countries.

When applied onto engine, Emission Control label must never be removed from engine block neither covered with a layer of paint. This label is the evidence showing that the engine is meeting U.S emissions regulations. It must be kept available at anytime once the vessel has entered waters being in the scope of the North American Emission Control Area (ECA).

Emission control system(s) laws

The U.S. EPA and CARB prohibit the removal or rendering inoperative of any device or element of design installed on or in engines/equipment in compliance with applicable emission regulations prior to or after the sale and delivery of the engines/equipment to the ultimate purchaser.

European Union (EU) declaration of emissions and conformity

The presence of an EU number on the label signifies that the Marine Diesel Engine has been certified with the European Union countries per Directives 97/68/EC as amended by Directive 2004/26/EC. The EU engine family is listed on the Emissions Label.

When installed in accordance with the manufacturer's instructions, Nanni Industries Marine Diesel Propulsion Engines without integral exhaust certified under Directive 97/68/EC as amended by Directive 2004/26/EC produce exhaust emissions of carbon monoxide, hydrocarbons, nitrogen oxides and particle emissions complying with the requirements of the Recreational Craft Directive 2003/44/EC.

NOTES

A series of horizontal dotted lines for writing notes.

S05 INSTRUMENTS

S05 INSTRUMENTS	35
DASHBOARD	36
DGBXXT09029 SI3 DIGITAL PANEL	36

S05 INSTRUMENTS

DASHBOARD

Nanni panel depends on your engine, refer to the manual corresponding to your panel.

DGBXXT09029 SI3 DIGITAL PANEL



S06 COMPONENTS

S06 COMPONENTS	37
ENGINE MAIN COMPONENTS	38
Engines views N13.CR3	39

S06 COMPONENTS

ENGINE MAIN COMPONENTS



NOTE !

Minor engine details may not be exactly as shown. Some components may not be part of the engine ordered. Not binding pictures.

P/N COMPONENTS

1	Oil filler
2	Fuel manual pump
3	Bleed nipples on fuel filter (2off)
4	Water separating prefilter for fuel
5	Fuel filter
6	Ventilating valve on the high pressure pump
7	Oil plug
8	Oil dipstick
9	Oil filler in cylinder block
10	Sea water intake
11	Sea water pump
12	Sacrificial anodes (2)
13	Charge air cooler
14	Holes for draining condensation in charge air cooler (on underside)
15	Expansion tank
16	Filling coolant
17	Level glass for checking coolant level
18	Thermostat
19	Oil filter
20	Centrifugal oil cleaner
21	Nipple for draining and filling coolant
22	Heat exchanger
23	Sea water outlet
24	Water cooled exhaust below
25	Coolant pump

S06 COMPONENTS

ENGINES VIEWS N13.CR3

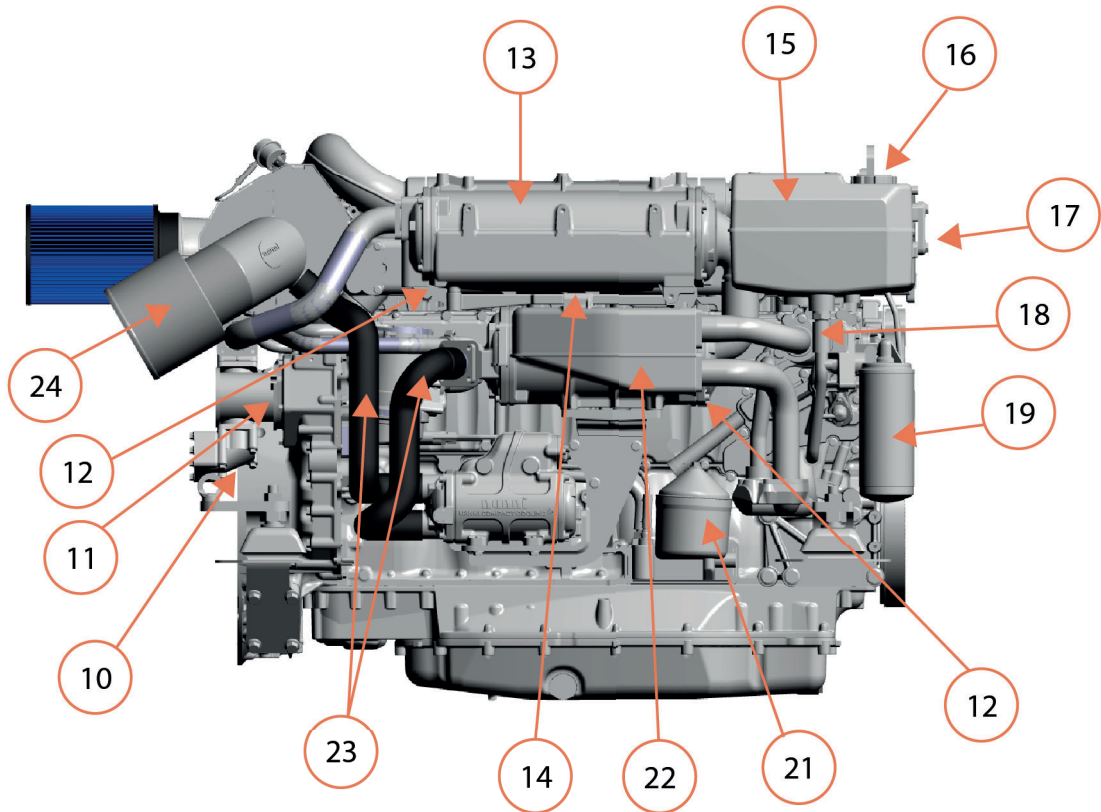
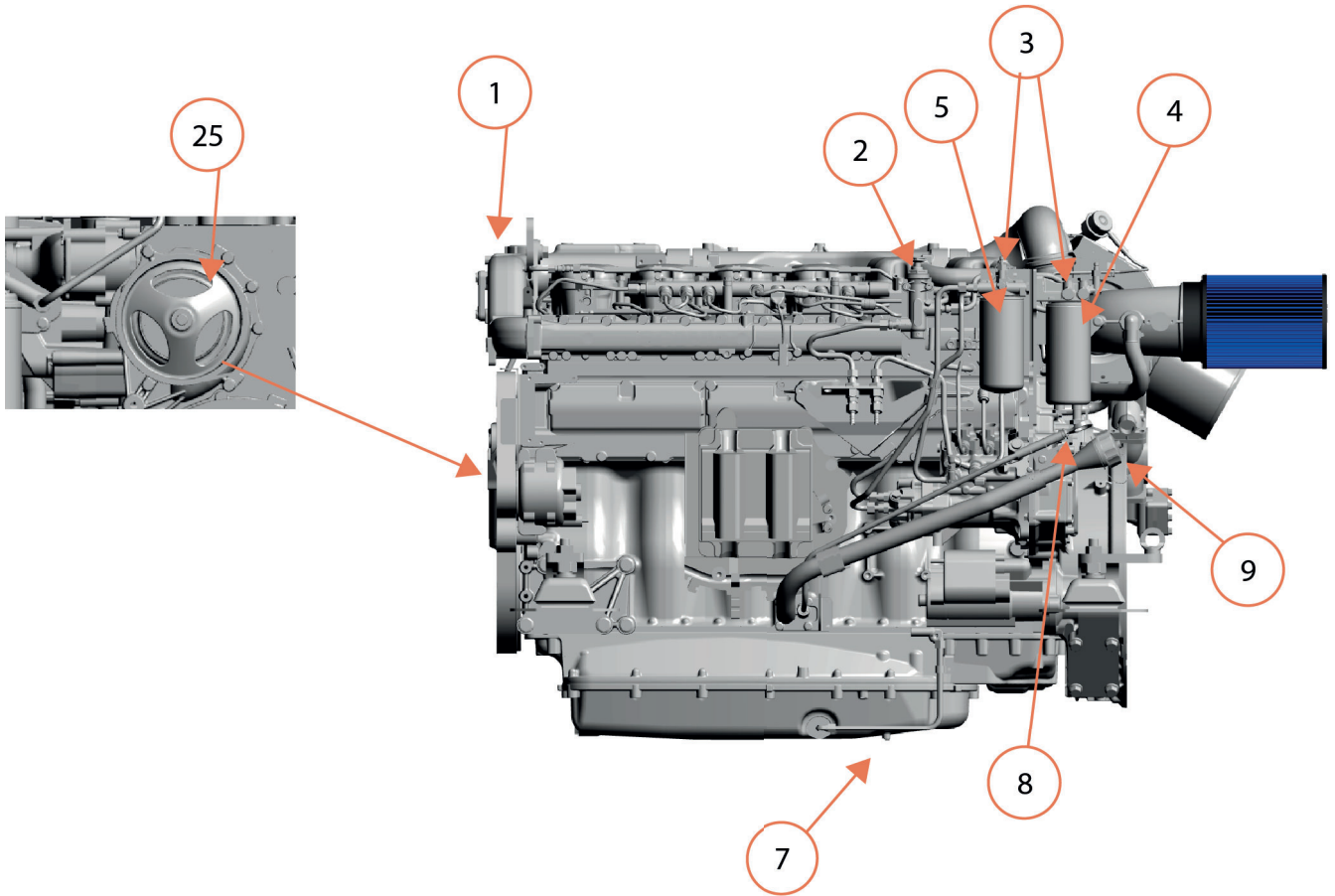

NOTES

A series of horizontal dotted lines for writing notes.

S07 START & RUNNING

S07 START & RUNNING	41
BEFORE STARTING	42
Fuel system	42
Raw water system	42
Electrical system	42
Neutral safeguard	42
Check before starting	43
STARTING THE ENGINE	43
Cold weather operation	43
Engine start	44
Ignition and cranking	44
Engine started	44
Starting with booster batteries	44
Engine reluctant to start	45
Idling engine	45
Normal engine operation	45
Break in	46
Power take off	46
Remote control	46
RUNNING	47
Behaviour of the boat	47
During operation	47
Cruising speed	47
Manoeuvring	48
Trolling valve	48
AFTER RUNNING	49
Stopping the engine	49
After stopping the engine	49
Anchoring	50
Cold weather precautions	50

S07 START & RUNNING

BEFORE STARTING

FUEL SYSTEM

The fuel is drawn from the tank by the fuel feed pump and is injected into the combustion chamber by the injection pump. A fuel filter is placed between the feed pump and the injection pump.

The injection pump delivers a larger amount of fuel than required for combustion. The fuel that is not burned is re-injected into the tank through an over-flow pipe.



ATTENTION !

The injection pump is an extremely precise unit. Water entry in the fuel system will cause major failure to the injection pump and to the whole fuel system.

A fuel prefilter with a water separator should be installed between the fuel tank and the fuel filter on the engine. The prefilter should be installed as close as possible to the engine fuel filter. It must never be installed on the engine as vibrations affect the water/fuel separation process.

If the fuel tank is located below the engine injection pump, an additional electric fuel feed pump should be installed between the prefilter and the feed pump of the engine.

RAW WATER SYSTEM

The raw water system allows to cool the engine coolant and the exhaust gas.

Raw water is drawn into the heat exchanger by the engine raw water pump. The raw water is drained via the exhaust elbow, where it is mixed with exhaust gases.

The siphon breaker prevents raw water entry into the cylinders via the raw water/exhaust system.



NOTE !

The use of a siphon breaker is mandatory if the exhaust elbow is under the waterline at full load or at less than 200 mm above it. A siphon breaker is mandatory in all Sail Boat and when there's a risk of water entry in the engine.

A raw water filter must be fitted between the raw water intake and the raw water pump of the engine.

ELECTRICAL SYSTEM

The engine extension harness should be away from any water projection and must be correctly attached as high as possible in the hold.

Engines in metallic hulls are generally fitted with a two-pole electrical system. This system allows to electrically isolate the engine from the electrical ground of the boat.

The alternator belt drives both the coolant pump and the alternator. Additional belt can also be fitted.

NEUTRAL SAFEGUARD

Once wired, the neutral safety switch from the engine control box will display a warning message on the SI-7, SI-9 or other similar control screen if transmission is engaged forward or backward before engine crank:

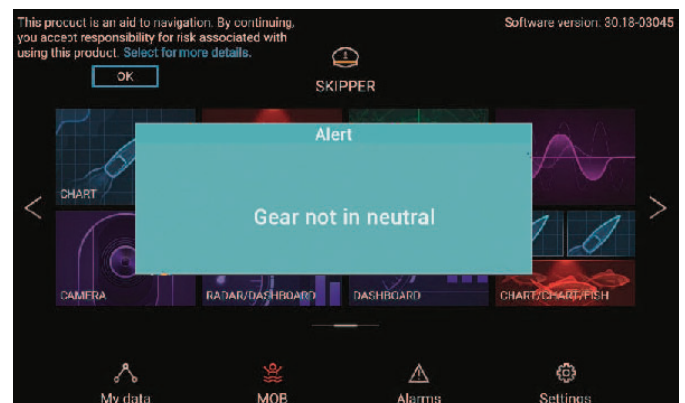

When this pop up appears, the engine will not start, unless transmission is put to neutral.

S07 START & RUNNING

CHECK BEFORE STARTING



WARNING !

Put all the protective covers back before starting the engine.



CAUTION !

Open the sea cock before starting the engine. The raw water pump impeller will be damaged if it runs dry even for few seconds, and may lead to engine overheating.

Perform all of the following operations before starting the engine:

1. Open sea cock. Prime the raw water system if necessary.

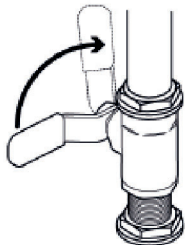

2. Start the compartment fan (if fitted) for at least five minutes. Otherwise, open the hold.
3. Check that there is sufficient fuel.
4. Move the control lever to the neutral position.
5. Open fuel cock, prime the system if necessary.
6. Check the engine and transmission oil level and fill with the recommended oil if necessary.
7. Check the coolant level, top up if necessary.
8. Check the mechanical control cables, lubricate as required.
9. Check there are no fuel, oil, coolant or water leaks.
10. Check the alternator belt.
11. Turn ON the main battery switch.

STARTING THE ENGINE



DANGER !

The propeller can cause serious injury when rotating. Check that nobody is in the water near the propeller before starting. Never use a start spray or any other equivalent product. These products are highly flammable.



CAUTION !

Always preheat the engine. Never race the engine while it is cold. Do not crank the engine continuously for more than 10 seconds at a time. Let it cool down for 2 minutes between cranking attempts. Failure to follow these guidelines may result in starter motor burnout.



NOTE !

If the engine does not start after 3 attempts, remove the key and drain the water in the waterlock. Failure to do so may lead to water ingress in the cylinders. When starting the engine for the first time, let it run at idle for several minutes and check for leaks or malfunction.

COLD WEATHER OPERATION



NOTE !

Engines may be equipped with coolant heaters as cold weather starting aids. Engine coolant heaters should be used when temperatures are at or below 0 °C (32 °F).

Turn on the engine coolant heater for a minimum of 2 hours before starting the engine. Additional information on cold weather operation is available from your Nanni engine distributor or authorized servicing dealer.

Synthetic oils improve flow at low temperatures, especially in Arctic conditions.

S07 START & RUNNING

ENGINE START

In the wheelhouse, turn the Key switch to energize the electronic system.

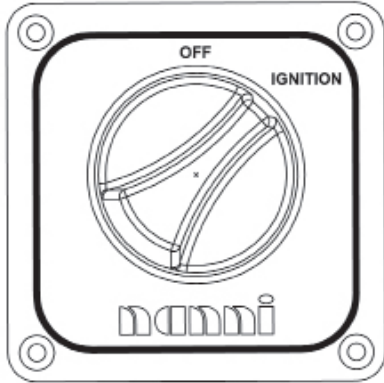

IGNITION AND CRANKING

Press the top right button on the SI-3 and the engine will crank.



Example of engine status display after cranking:

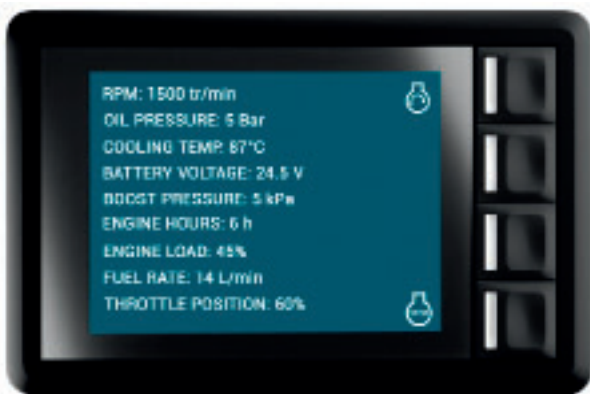

ENGINE STARTED

To insure adequate lubrication, operate engine at or below 1200 rpm with no load for 1-2 minutes. Extend this period to 2-4 minutes at freezing or sub-zero temperatures.

1. Check oil pressure gauge as soon as engine starts. If gauge needle does not level up to minimum oil pressure specification within 5 seconds, stop the engine and determine the cause.
2. Watch coolant temperature gauge. Do not place engine under full load until properly warmed up.

It is a good practice to operate the engine under a lighter load and at lower speeds than normal for the first few minutes after start-up.

STARTING WITH BOOSTER BATTERIES



CAUTION !

Make sure to use batteries with the same rated voltage as the engine's system voltage. On an engine with a two pole electrical system, connect the other end of the jumper cable to the negative pole (-) of the booster battery.

1. Connect the jumper cable to the positive pole (+) of the flat battery, then to the positive pole (+) of the booster battery.
2. Connect the jumper cable to the negative pole (-) of the booster battery. Connect the other end to a bolt of the engine block.

Start the engine following the starting procedure:

3. Let the engine run at idle for few minutes to charge the battery.
4. Stop the engine and remove the cables in the exact reverse order from installation.

S07 START & RUNNING

ENGINE RELUCTANT TO START

If a water lift (water lock) muffler is installed on the exhaust line, excessive cranking could cause seawater to enter the cylinders and damage the engine. To start engine, reduce starting attempts to three and if not OK, undertake to do this:

1. Close the seacock to avoid filling the muffler with water.
2. Try to start the engine by following the regular starting procedure.
3. When the engine does start, stop the engine immediately and turn off the switch.
4. Re-open the seacock and restart the engine.

IDLING ENGINE

Avoid excessive engine idling as it may cause the coolant temperature to fall below its normal range. This, in turn, causes crankcase oil dilution, due to incomplete fuel combustion, and permits formation of gummy deposits on valves, pistons, and piston rings. It also promotes rapid accumulation of engine sludge and unburned fuel in the exhaust system.

Once an engine is warmed to normal operating temperatures, engine should be idled at slow idle speed. Slow idle speed for engine is set at the factory. If an engine is left idling for more than 5 minutes, stop and restart later.

NORMAL ENGINE OPERATION

Check engine coolant temperature and oil pressure. Temperatures and pressures will vary between engines and with changing operating conditions. If coolant temperature rises above the maximum coolant temperature, reduce load on engine. Unless temperature drops quickly, stop engine and determine cause before resuming operation.

Operate the engine under a lighter load and at slower than normal speed for first 15 minutes after start-up. DO NOT run engine at slow idle unless necessary for manoeuvring out of dock and harbor.

Stop engine as soon as possible if there are any signs of part failure. Symptoms that may be early signs of engine problems are:

- Sudden drop in oil pressure
- Abnormal coolant temperatures
- High marine gear oil temperature
- Unusual noise or vibration
- Sudden loss of power
- Excessive black exhaust
- Excessive fuel consumption
- Excessive oil consumption
- Fluid leaks



Above: typical temperature and pressure Type 5 and 4 gauges

S07 START & RUNNING

BREAK IN

Operate the engine with care for the first 50 hours of operation.

Do not race the engine while it is cold. Do not operate it at full load except for short periods. Never run the engine at constant engine speed for long periods during the break in period.

Check the oil and coolant level frequently during the running-in period. The oil consumption can be more important during the running in period.

See [Maintenance](#) section.

POWER TAKE OFF

Some engines can be fit with a Power Take Off system. This system allows to power accessories like bilge pump, watermaker, etc.

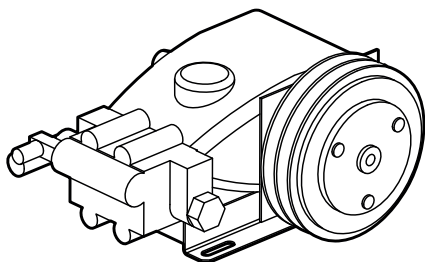

NOTE !

Any mechanical power taken from the engine from a PTO reduces the power delivered to the propeller. The use of a PTO should always be studied and approved by the R&D department of Nanni Industries S.A.S France. Contact your Nanni dealer for more informations.

REMOTE CONTROL

The remote control is an optional extra not in the scope of supply of the engine. The remote control installed on the boat can be different than the ones shown in this document.

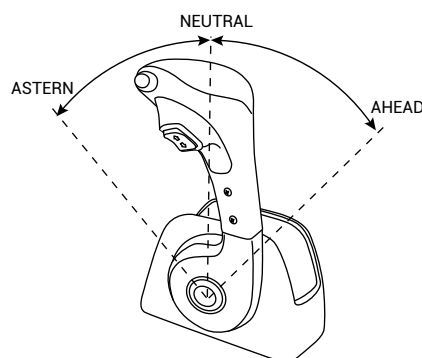
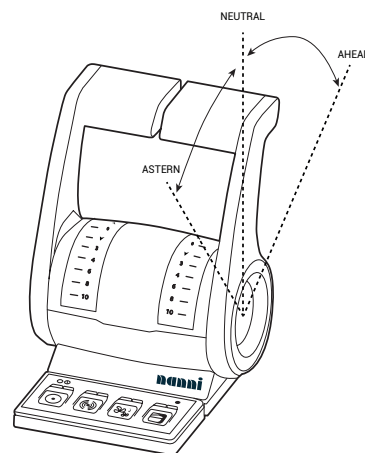

On most boats, the control lever controls both the engine rpm and the gear shift (ahead / astern). However, some boats can be equipped with a separated shift command.

It can also be fitted with a neutral safety switch that prevents the engine from starting until the lever is in neutral position.

Consult the boat builder or your Nanni dealer if you are not sure about the operation of the remote control.

S07 START & RUNNING

RUNNING

BEHAVIOUR OF THE BOAT

If this is your first boat or if you are not familiar with the boat, we urge you to practice controlling the boat at slow speed as a first step. Avoid violent manoeuvres or unexpected speed changes while sailing. People can fall over or overboard.

Keep also in mind that the weight distribution (passengers, equipments, etc.) inside the boat has an impact on the behaviour of the boat when cruising. Depending the position of the load, the behaviour of the boat may change, particularly in the case of a planning hull.

The condition of the hull and the propeller is also a critical factor. A dirty and / or damaged hull will modify the behaviour of the boat and therefore the engine performance. It can also cause cavitation which can seriously erode the surface of the propeller, the drive, etc.

DURING OPERATION



NOTE !

Never press the START button when the engine is running.

The solenoid of the starter motor would push up the cog and make the starter motor to start, against the turning flywheel of the engine already in motion. This action would destroy the starter motor.

Check the instruments and warning lamps after starting, and regularly when cruising.

CRUISING SPEED

A recommended engine speed is given in the TECHNICAL DATA section to help you to set your cruising speed.



NOTE !

Always consider sailing conditions and load of the boat to set the cruising speed.

Operating the engine at wide open throttle should be avoided since it is both uncomfortable and uneconomical. Note that operating the engine at a too low rpm for a long period could lead among other things to increased oil consumption.

Deposits may also form in the injection system if the engine do not reach its nominal operating temperature regularly. Run the engine at full throttle regularly in order to burn off any possible deposits in the fuel system.

S07 START & RUNNING

MANOEUVRING



WARNING !

Shifting at high speed can damage both the engine and the transmission and be dangerous for passengers.



CAUTION !

On a twin engine boat, both engines should be started during reversing manoeuvres to reduce the risk of water ingress in the stationary engine.

Carry out the following operations for forward / reverse manoeuvres:

1. Reduce engine speed to idling and, if possible, let the boat lose most of its speed.
2. Move the control lever to the neutral position and wait a few seconds.

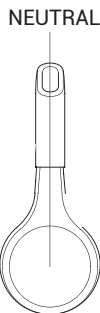

3. Move the control lever into astern. Increase the speed.

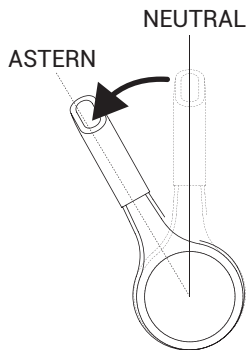

TROLLING VALVE

The Trolling valve system allows to reduce the rotation speed of the propeller below its speed when the engine is at idle. The boat speed is reduced by 30% to 70%.



CAUTION !

The Trolling valve system must never be used for manoeuvring. It also must never be used at an engine speed of more than 1200 rpm (refer to Gear Box operating manual).

S07 START & RUNNING

AFTER RUNNING

STOPPING THE ENGINE



CAUTION !

Never stop the engine by using the main switch. This could damage the electrical system.

Before stopping the engine, let it run at idle in neutral for few minutes, especially if the engine has been operated at high speed and load. This will allow the coolant to cool down the engine.

1. Start the fan in the engine compartment (if fitted) or open the hold.
2. Turn the key of the starter switch counter-clockwise, the engine stops and all indicators turn off. The engine stops, all lamps go out. For panel without key, press the ON/STOP button and release it. The engine stops. Turn the key of the main panel counter-clockwise. All indicators will turn off.

AFTER STOPPING THE ENGINE



CAUTION !

Even after the engine has stopped, some components and fluids will remain hot and under pressure for several minutes. As far as possible, limit works on the engine immediately after stopping it. Allow it to cool down first.

After the engine has stopped:

1. Turn off the main switch.
2. Close the sea cock and the fuel cock.

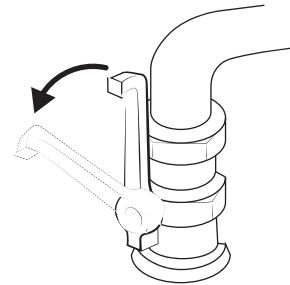

3. Inspect the engine compartment and check for leaks.

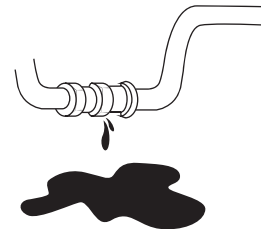

CAUTION !

If the boat is being towed, put the lever in neutral, stop the engine and close the sea cock to prevent the engine from being filled with raw water.

On a twin-engine boat, if cruising with a single engine, close the sea cock of the stopped engine.

Do not forget to open the sea cock before restarting the engine.

S07 START & RUNNING

ANCHORING

If the boat is not going to be used for some time but is being left in the water, the engine must be run to operating temperature at least once every 2 weeks. This prevents corrosion in the engine.

When the boat is at anchor or in port for an extended period of time, vegetation may develop on the hull, the keel, the drive, the rudder, the propeller, etc. It will significantly affect the behaviour of the boat and the performance of the engine if the vegetation is not removed before the next time the boat is used.

Vegetation and fouling can also obstruct the raw water system and result in damage to the engine by overheating.

Inspect and clean the boat and the raw water system each time the engine is used. Clean if necessary. If the boat is removed out of water, clean the hull and spray a coat of anti-fouling. Never paint the anodes.

Furthermore, when the boat is at anchor or in port for an extended period, water can fill the exhaust system via the exhaust outlet. It is necessary to drain regularly the waterlock when the boat is at anchor.

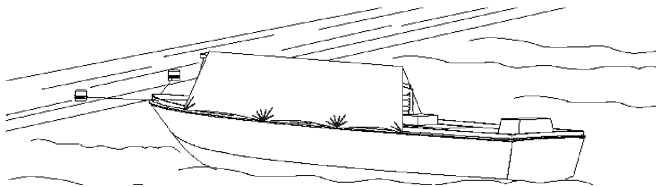

COLD WEATHER PRECAUTIONS

See [Maintenance](#) Section for complete details.



CAUTION !

A poorly charged battery may burst as a result of freezing.

S08 MAINTENANCE

S08 MAINTENANCE	51
ABOUT	52
GENERALITIES	52
MAINTENANCE INTERVALS	54
MAINTENANCE INTERVALS	55
TURBOCHARGER	56
Turbo service	56
CLEANING THE ENGINE	57
EXHAUST SYSTEM	57
AIR INTAKE	58
Air cleaner	58
Reading vacuum indicator	58
Replace the air cleaner filter and safety cartridge	59
Renewing an air filter with a non-renewable element	59
FUEL SYSTEM	60
Cleanliness requirements	60
Checking fuel level	61
Renewing the fuel filter	61
Draining and renewing an engine-mounted water separating prefilter	62
Draining and renewing the single water separating prefilter (option)	62
Draining the commutative water separating prefilter (option)	64
Renewing the commutative water separating prefilter (option)	65
Bleeding the fuel system	66
LUBRICATION SYSTEM	68
Oil level - adding engine oil	68
Changing the oil	69
Cleaning centrifugal oil cleaner	70
Operational testing of the centrifugal oil cleaner	72
Replace the oil filter	73
COOLING SYSTEM	74
Coolant	74
Checking coolant level	75
Checking coolant antifreeze and corrosion protection	75
Checking sacrificial anodes	76
Checking sea water pump impeller	76
Changing the coolant and cleaning the coolant system	77
ELECTRICAL SYSTEM	84
Wires and connectors	84
Engine command connectors	84
BATTERY	85
Keep clean the battery	85
Disconnect the starter cables	85
Connect the cables	85
Battery electrolyte level	85
Electrolyte level check	86
MISCELLANEOUS	87
Drive belt	87
Checking for leaks	88
Checking and adjusting the valve clearance	89

ABOUT



This section is describing preventive maintenance operations to be carried out by the owner/operator of the engine. This is not a part of a workshop repair manual.

Carrying a set of preventive maintenance operations in accordance with the service intervals will ensure engine optimal reliability and service life.

During the warranty period, it is essential to get any work carried out by a Nanni authorized workshop. Furthermore, any service should be registered in the Nanni after-sale system.

However, some regular checks, particularly those made every time the engine is used, are of the duty of the user. Some operations are explained further on for you to work on the engine in case of an emergency or if there is no repair workshop nearby.

We recommend to have all your works checked by a Nanni authorized workshop.

Repairs and/or adjustment works on the engine by unseasoned marine trained technicians is forbidden for obvious safety reasons. Improper works endangers life, even not at open sea. Operations on valve timing and injection system belong to the exclusive domain of Nanni trained representatives. These may be against EPA or other worldwide environmental regulations.



NOTE !

The service intervals and relevant informations about the preventive maintenance of the transmission are indicated in the user manual provided by the manufacturer of the transmission. Contact your Nanni representative for further information regarding the maintenance of the transmission.

GENERALITIES



WARNING !

Perform maintenance operations having the engine stopped and cold. Get the starting key out from the panel, put it in your pocket and turn off the power supply.

Read this whole chapter and take all safety precautions before contemplating any maintenance or repair work. Make sure you understand how to perform every operation.



CAUTION !

Clean the engine before any maintenance. Watch for any oil or fluid drop as it is an evidence of a leak somewhere.



CAUTION !

Do not let oil, fuel or grease deposits build up around the engine as they may increase the risk of fire in the engine compartment. Furthermore, these deposits may hide potential heavy unseen failures.

MAINTENANCE

The maintenance schedule covers a number of points divided into several sections:

- Lubrication system.
- Air cleaner
- Cooling system
- Fuel system
- Various



WARNING !

Prior to any work onto the engine, the starting motor command must be disabled first. Alternatively, a related electric cable may be removed. Should the engine starts unexpectedly, there is a serious risk of injury. There is always a risk of sustaining burns when an engine is hot. Particularly hot parts are engine manifolds, turbochargers, oil sumps, as well as hot coolant and oil in pipes and hoses.



IMPORTANT !

Upon delivery, the engine is optimised for the proposed application.

However, regular maintenance is necessary to:

- Prevent unplanned stops
- Extend the service life of the engine
- Maximise the long-term emission performance of the engine
- Provide the best possible operating economy.

MAINTENANCE INTERVALS

ENGINES N13.700 CR3 HD, N13.700CR3, N13.750 CR3, N13.800 CR3, N13.930 CR3.

The maintenance program includes the following:

- R maintenance : one event when taken into service
- S maintenance : minimum basic maintenance
- M maintenance : more extensive maintenance
- L maintenance : includes nearly all maintenance items in the form
- XL maintenance : includes all maintenance items in the form

During a period, the sequence is S-M-S-L-S-M-S-L-S-M-S-XL

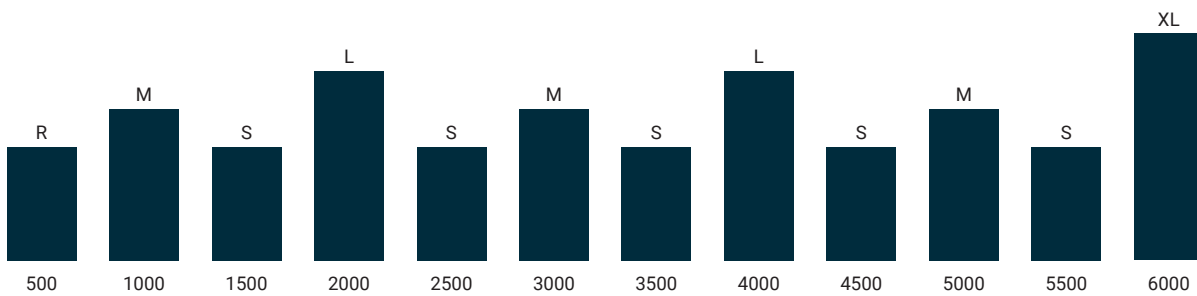

ELEMENT	COMPONENT	Daily	1st time at		Interval (hours)					Minimum	
			1st start	500	500	1000	2000	6000	Yearly	every 5 years	
				R	S	M	L	XL			
Air Cleaner	Reading the vacuum indicator	◇		◇	◇	◇	◇	◇			
	Renewing the filter element						◇	◇			◇
	Renewing the safety cartridge						◇	◇			◇
	Renewing air filter with a non-rewebeable element						◇	◇			◇
Lubrication	Checking the oil level	◇	◇								
	Changing the oil			◇	◇	◇	◇	◇	◇		
	Cleaning the centrifugal oil cleaner			◇	◇	◇	◇	◇	◇		
	Renewing the oil filter			◇	◇	◇	◇	◇	◇		
Cooling system	Checking the coolant level	◇	◇	◇	◇	◇	◇	◇			
	Checking coolant antifreeze and corrosion protect		◇				◇	◇	◇		
	Checking sacrificial anodes			◇	◇	◇	◇	◇	◇		
	Checking the sea water pump impeller			◇	◇	◇	◇	◇	◇		
	Changing the coolant and cleaning the cooling system							◇			◇
Fuel system	Checking the fuel level	◇	◇								
	Draining the water separating prefilter	◇		◇	◇	◇	◇	◇			
	Renewing the fuel filters			◇	◇	◇	◇	◇			◇
Miscellaneous	Checking the drive belt		◇			◇	◇	◇	◇		
	Checking for leaks	◇		◇	◇	◇	◇	◇			
	Checking and adjusting the valve clearance			◇			◇	◇			

* Operations to be performed in accordance with user and maintenance manual for your engine. For all technical information specific to your engine, refer to the user and maintenance manual.

MAINTENANCE INTERVALS

ENGINE N13.900 CR3 (RATING M6.S)

The maintenance program includes the following:

- R maintenance : one event when taken into service
- S maintenance : minimum basic maintenance
- M maintenance : more extensive maintenance
- L maintenance : includes nearly all maintenance items in the form
- XL maintenance : includes all maintenance items in the form

During a period, the sequence is S-M-S-M-S-L-S-M-S-M-S-L-S-M-S-M-S-L-S-XL

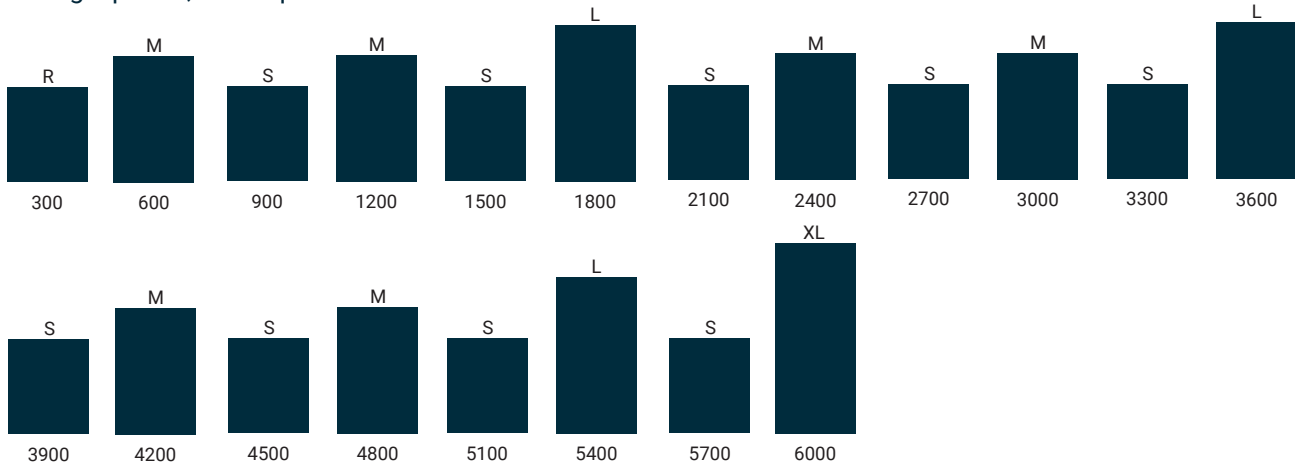

ELEMENT	COMPONENT	Daily	1st time at		Interval (hours)					Minimum	
			1st start	300	300	600	1800	6000	Yearly	every 5 years	
				R	S	M	L	XL			
Air Cleaner	Reading the vacuum indicator	◇		◇	◇	◇	◇	◇			
	Renewing the filter element						◇	◇			◇
	Renewing the safety cartridge						◇	◇			◇
	Renewing air filter with a non-rewebable element						◇	◇			◇
Lubrication	Checking the oil level	◇	◇								
	Changing the oil			◇	◇	◇	◇	◇	◇	◇	
	Cleaning the centrifugal oil cleaner			◇	◇	◇	◇	◇	◇	◇	
	Renewing the oil filter			◇	◇	◇	◇	◇	◇	◇	
Cooling system	Checking the coolant level	◇	◇	◇	◇	◇	◇	◇			
	Checking coolant antifreeze and corrosion protect		◇				◇	◇	◇		
	Checking sacrificial anodes			◇	◇	◇	◇	◇	◇	◇	
	Checking the sea water pump impeller			◇	◇	◇	◇	◇	◇	◇	
	Changing the coolant and cleaning the cooling system								◇		◇
Fuel system	Checking the fuel level	◇	◇								
	Draining the water separating prefilter	◇		◇	◇	◇	◇	◇			
	Renewing the fuel filters			◇	◇	◇	◇	◇			◇
Miscellaneous	Checking the drive belt		◇				◇	◇	◇	◇	
	Checking for leaks	◇		◇	◇	◇	◇	◇			
	Checking and adjusting the valve clearance			◇				◇	◇		

* Operations to be performed in accordance with user and maintenance manual for your engine. For all technical information specific to your engine, refer to the user and maintenance manual.

TURBOCHARGER



CAUTION !

A turbocharger is an exhaust-driven mechanical device that boost engine power by pumping more air into the engine. A turbocharger uses a pair of fan-like castings mounted on a common shaft. One (called the turbine) is piped to the exhaust, while the other (the compressor) is piped to the engine intake. The flow of exhaust spins the turbine, which causes the compressor to turn. The compressor serves to blow air into the engine at a greater rate than it can pull in on its own. The greater volume of air can be mixed with a greater volume of fuel, which increases the power output.

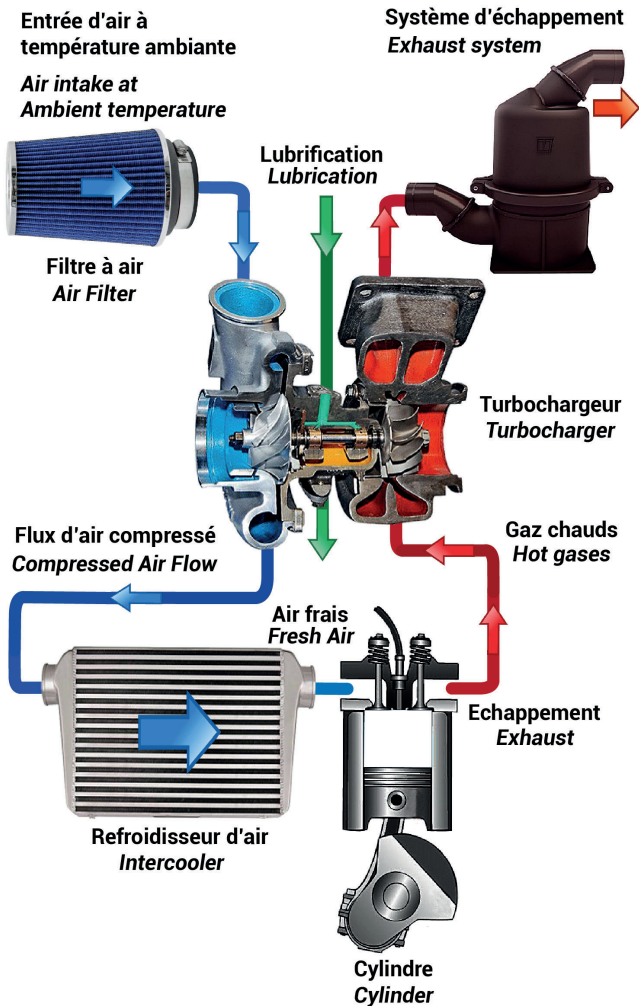

Principle of operation of a turbocharger.

TURBO SERVICE

Engine turbochargers are designed to provide long years of trouble free service, which if required, can only be performed by a specialized workshop. In view to maintain turbochargers performances for as long as possible, some basic rules must be followed.

Changing or cleaning the air filters on a regular basis is a good way to keep debris from causing problems with the intake side of turbochargers.

A turbocharged engine will definitely need more oil changes than an ordinary atmospheric one, as the turbines axle requires excellent lubrication. For this reason, oil characteristics must be followed closely. Never use low grade bargain lubrication oil.

Turbochargers get very hot when engine is running and a protective metal shield or thermal sleeve is always affixed onto the exhaust side to prevent burns. Never remove these shields.

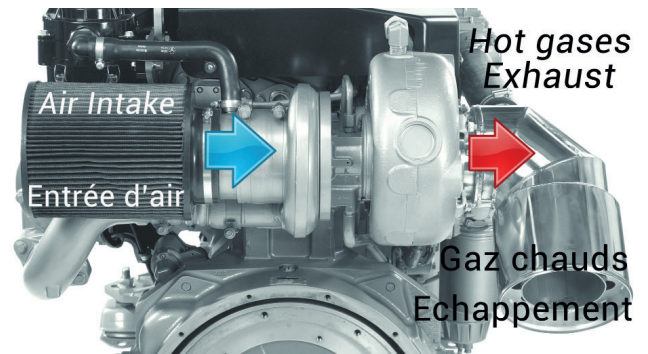

Above picture: Turbo & Air intake



IMPORTANT !

There is no serviceable part for the end user inside turbochargers. Any attempt to disassembling would lead to a total failure.

CLEANING THE ENGINE



CAUTION !

Beware of hot washing water. Wear eye protection, protective clothes and protective gloves.

Clean the engine before maintenance. Wipe away sludge.

Clean only the engine with sprayed hot water if it can be drained through a dedicated port.

Use a degreasing agent, if necessary.

Take care not to spray or pour any water inside the dashed line below:

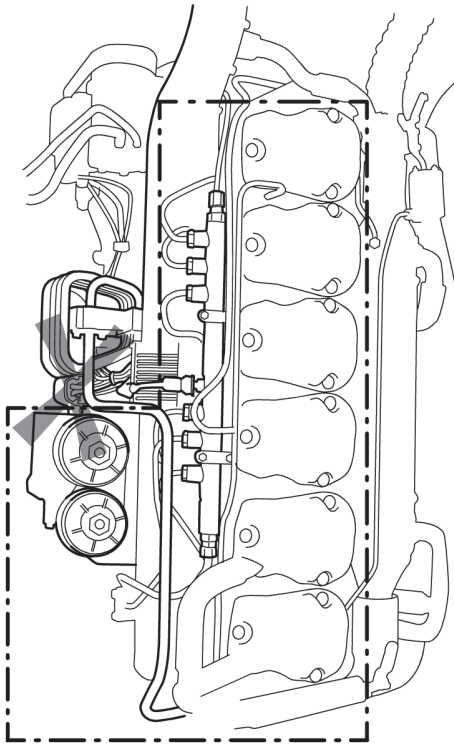

Clean within the area marked by the line

EXHAUST SYSTEM

The exhaust system of an engine must be able to freely exhaust all exhaust gases at high temperatures after combustion in the outside air.

The exhaust resistance should be as low as possible to avoid a decrease in power, however the exhaust noise should be kept to an acceptable level. Careful design is necessary to reconcile these two contradictory factors.

Exhaust manifold exhaust may be either introduced directly into the silencer or conveyed to a location that will not interfere with the operator through the exhaust pipe. The goal is, in all cases, to reduce the back pressure.

Inspect the exhaust system as a whole (hoses, hose clamps, mixing elbow, manifold, etc.). Look for cracks, leaks and rust. Tighten or change if necessary.

Check that there are no carbon deposits or soot on the exhaust components as this is a decisive sign of an exhaust leak.

If any fault appears on any part of the exhaust system, replace it as there is a risk of leakage from the exhaust or water entering the engine.

When disassembling the exhaust system, replace the seal (s).

AIR INTAKE



WARNING !

Carry out these operations when the engine is stopped and cold. Make sure that no dust or dirt enter the intake manifold.

The reliability and the performances of the engine depend among other things on the quantity and the temperature of the global air intake design.

AIR CLEANER



WARNING !

Never start the engine without the air filter in position. Without the air filter, there is a risk of dirt being sucked into the engine.

The engine turbocharger will continue to rotate and take in air for a time, even after the engine has stopped. Therefore, wait for a few minutes before opening the air cleaner.



NOTE !

Renew the filter element earlier than the maintenance interval if the vacuum indicator shows red.

The filter element must not be cleaned in water or be blown clean with compressed air. There is always a risk that the filter element will be damaged when it is cleaned.

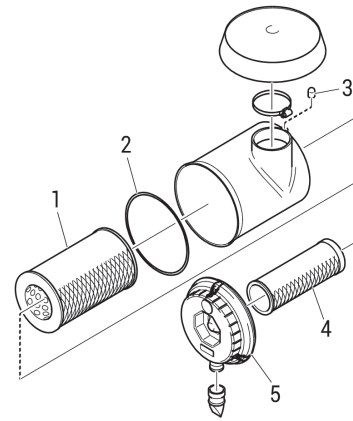

Air cleaner with safety cartridge.

1. Filter element.
2. O-ring.
3. Vacuum indicator.
4. Safety cartridge.
5. Cover.

READING VACUUM INDICATOR

If the vacuum indicator's red plunger is fully visible, renew the air cleaner filter element in accordance with the following section.

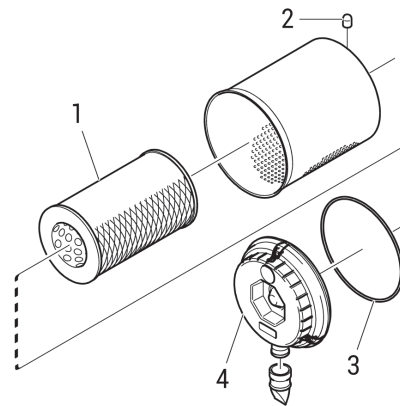

Air cleaner without safety cartridge.

1. Filter element.
2. Vacuum indicator.
3. O-ring.
4. Cover.

S08 MAINTENANCE

REPLACE THE AIR CLEANER FILTER AND SAFETY CARTRIDGE

Special tool

Number	Description	Illustration
970317077	Kit air filter cleaner EN, ESP, SUOMI	
970317078	Kit Air filter cleaner FR, IT, DEU	

1. Remove the cover from the air cleaner.
2. Renew the filter element.
3. If the air cleaner has a safety cartridge: Remove the safety cartridge and fit a new one.
4. Insert a torch into the filter element and check that the filter paper is free of holes and cracks.
5. Renew the O-ring if it is damaged or hard.
6. Assemble the air cleaner.
7. Ensure that the O-ring is not outside the edges.
8. Reset the vacuum indicator by pressing in the button marked in the illustration.

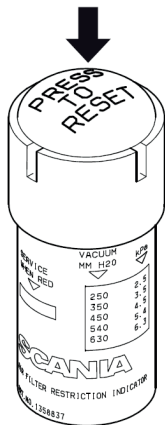

RENEWING AN AIR FILTER WITH A NON-RENEWABLE ELEMENT



IMPORTANT!

If the engine has an air filter with a non-renewable Nanni element, it should be renewed instead of cleaned.

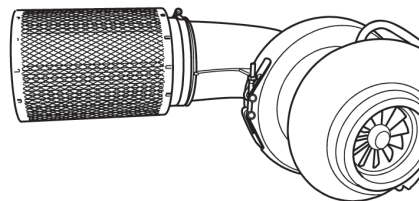

Air filter with a non-renewable element.

FUEL SYSTEM



DANGER !

Stop the engine and let it cool down before refuelling or carrying out any operation on the fuel system.



CAUTION !

Fuel is flammable and can be dangerous. Fuel spilled on hot surfaces or near sparks can ignite. Do not step onto the injection piping. Take care to always keep them in good condition.



WARNING !

Total cleanliness must be guaranteed when working on the fuel system. No impurities should enter the injection system. Make sure not to spill fuel on nearby hoses.



NOTE !

Any work on the fuel injection system must be carried out by a authorized Nanni technician. Check regularly the condition of the components of the fuel system (hoses, filter, clamps, etc). When a clamp is removed, replace it by a new one, always in stainless steel.



WARNING !

The fuel feed pump is an extremely precise unit. Water entry in the fuel system will cause major failure to the injection pump and to the whole fuel system.

CLEANLINESS REQUIREMENTS



IMPORTANT !

The whole fuel system is very sensitive to dirt and even very small particles. Foreign particles in the system can cause serious malfunctions. It is therefore very important that everything is as clean as possible when work is carried out on the fuel system. Before repair work, the engine must be washed. If possible, a hot water wash should be used.

It is strictly forbidden to carry out any machining work or work with compressed air near an open fuel system. Be extra careful and always use clean, lint-free and dust-free clothes and disposable gloves when working on the fuel system.

Clean tools before they are used and do not use any worn or chrome-plated tools. Material and flakes of chrome may come off.

Clean connections and the surrounding area before removal. When cleaning, cloths or paper which shed fibres must not be used.

Plug or cover the connections during removal. Also clean the connections before the components are fitted. Place removed components on a thoroughly cleaned, dust-free surface.

CHECKING FUEL LEVEL

Check the fuel level and top up with fuel as necessary.



NOTE !

If the fuel tank has been run dry or if the engine has not been used for a long time, bleed the fuel system. See the section [Bleeding the fuel system](#).

RENEWING THE FUEL FILTER

1. Clean the exterior of the fuel filter with a damp cloth.
2. Unscrew the filter.
3. Apply oil to the gasket on the new filter.
4. Screw the filter into place by hand until it makes contact.
5. Screw a further half turn by hand.
6. Bleed the fuelsystem according to the instructions in the [Bleeding the fuel system](#) chapter.

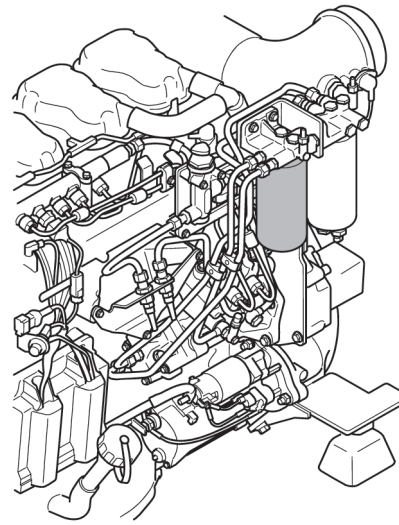

Fuel filter location

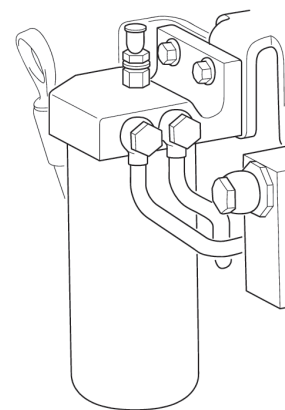

Fuel filter

S08 MAINTENANCE

DRAINING AND RENEWING AN ENGINE-MOUNTED WATER SEPARATING PREFILTER



IMPORTANT !

The sensor cable is sensitive. Handle it carefully.

1. Close the shut-off cock in the fuel pipe and position a container under the filter
2. Detach the sensor cables from the contact housings on the filters.
3. Open the filter drain plugs and allows the fluid to run down into the container.
4. Unscrew the filters (3) from the filter head (4).

1. Filter head.
2. Filter.
3. Contact housing.
4. Drain plugs.

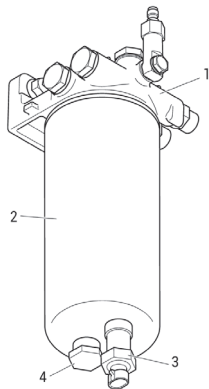

5. Discard the old filters and use new ones.
6. Lubricate the O-rings on the filters with engine oil.
7. Fill the width of the filters with clean fuel.
8. Screw the filters into position until the O-rings rest against the filter head.
9. Tighten the filters by hand a further half-turn.
10. Open the shut-off cock in the fuel pipe and check that the fuel system is sealed.
11. Connect the sensor cable to the contact housings on the filters.
12. Bleed the fuel system according to the instructions in the [Bleeding the fuel system chapter](#).

DRAINING AND RENEWING THE SINGLE WATER SEPARATING PREFILTER (OPTION)



IMPORTANT !

The sensor cable is sensitive. Handle it carefully.



Use a suitable container. The fuel collected must be disposed of as specified in national and international laws and regulations.

Before starting work: Close the shut-off cock in the fuel pipe and position a container under the filter.

1. Sensor cable.
2. Drain tap.
3. Filter cover.
4. Filter.

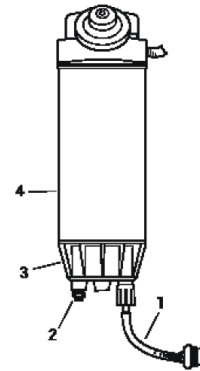

1. Undo the sensor cable from the connector on the filter bracket.
2. Open the drain tap in the filter cover and let the fluid run down into the container.
3. Unscrew the filter cover.
4. Unscrew the filter from the filter head.
5. Discard the old filter and use a new filter.
6. Lubricate the O-ring in the filter cover with engine oil.
7. Screw the filter cover onto the new filter by hand. Make sure that the drain tap is fully closed.
8. Lubricate the O-ring on the filter with engine oil.

S08 MAINTENANCE

9. Fill the width of the filter with clean fuel.
10. Screw the filter into position until the O-ring rests against the filter head. Tighten the filter another 1/2 to 3/4 turn by hand.
11. Open the shut-off cock in the fuel pipe and check that the fuel system is sealed.
12. Screw the sensor cable in the contact housing onto the filter bracket.
13. Bleed the fuel system according to the instructions in the [Bleeding the fuel system](#) section.

S08 MAINTENANCE

DRAINING THE COMMUTATIVE WATER SEPARATING PREFILTER (OPTION)

During operation, the arrow on the rotary control should point towards the filter being used.



Use a suitable container. The fuel collected must be disposed of as specified in national and international laws and regulations.

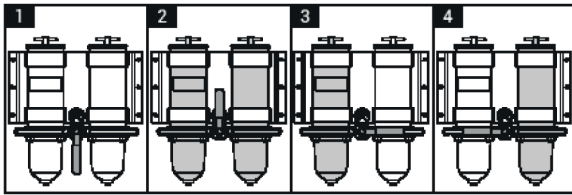

1. Closed; neither filter is active.
2. Both filters are active.
3. Left-hand filter is active.
4. Right-hand filter is active.

1. Switch off the filter that needs renewing. The arrow on the rotary control points towards the filter in operation.



WARNING !

Be careful that the valve does not pass the closed position when the engine is in operation. A closed position can result in the engine stopping.

2. Remove the cover from the filter housing.

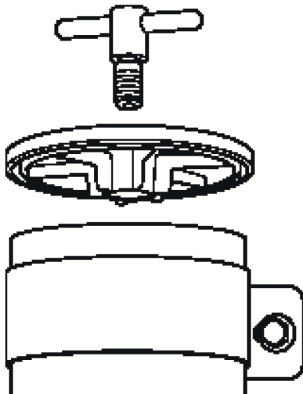

3. Undo the drain plug.
4. Tighten the drain plug when all the water has emptied.



5. Fill the filter housing with clean fuel.
6. Fit the cover. Tighten the cover screw by hand.

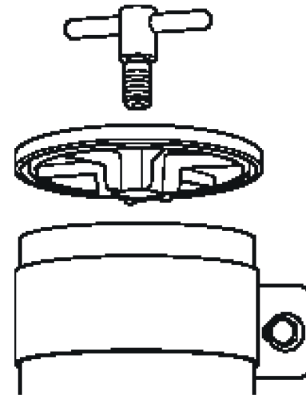

S08 MAINTENANCE

RENEWING THE COMMUTATIVE WATER SEPARATING PREFILTER (OPTION)

During operation, the arrow on the rotary control should point towards the filter being used.



Use a suitable container. The fuel collected must be disposed of as specified in national and international laws and regulations.

1. Switch off the filter that needs renewing. During renewal, the arrow on the rotary control points towards the filter in operation.



WARNING !

Be careful that the valve does not pass the closed position when the engine is in operation. A closed position can result in the engine stopping.

2. Clean the filter housing externally with a cloth.
3. Remove the cover from the filter housing.

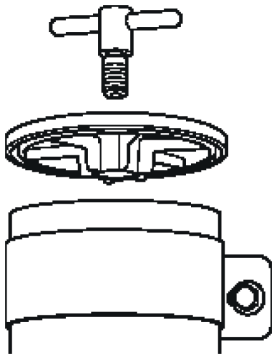

4. Remove the filter and fit the new filter.

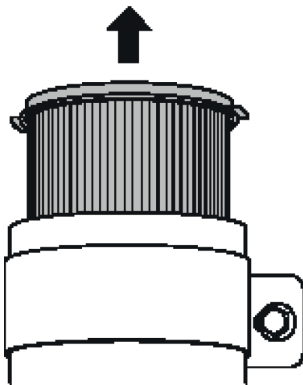

5. Renew the O-rings in the cover.
6. Lubricate the O-rings with engine oil.

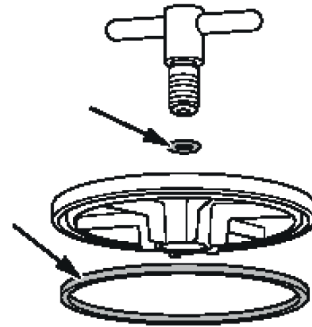

7. Fill the filter housing with clean fuel.
8. Fit the cover. Tighten the cover screw by hand.

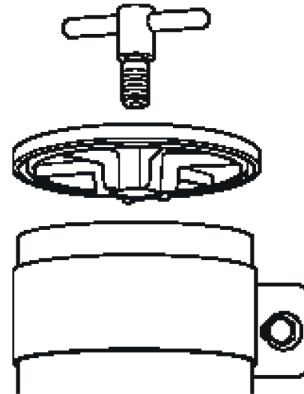

BLEEDING THE FUEL SYSTEM

BLEEDING THE FUEL SYSTEM USING A SUCTION TOOL

Tool

Description	Illustration
Suction tool for fuel system	



NOTE !

Nanni recommends bleeding the fuel system using suction tools rather than with a hand pump. This is a quicker and simpler method, which ensures a complete bleeding.

1. Open the ventilating valve on the high pressure pump and connect the suction tool to it. See illustration. Start by wiping off the ventilating valve.
2. Hold the suction tool straight and draw out at least a full container of fuel.
3. Once the fuel coming out of the hose is free of air bubbles, then bleeding is complete.
4. Close the ventilating valve on the high pressure pump. Remove the hose and suction tool.
5. Start the engine and check that no leakage occurs.

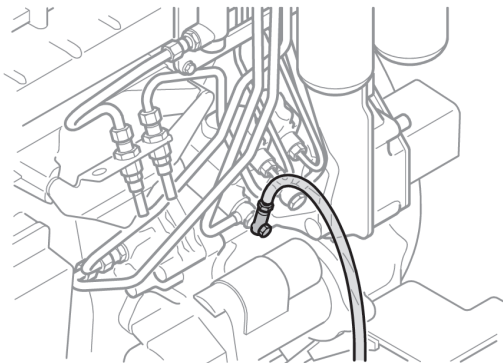

BLEEDING THE FUEL SYSTEM USING A HAND PUMP

Tightening torques	
Ventilating valves	9 Nm (7 lb-ft)

1. Unscrew the hand pump handle.

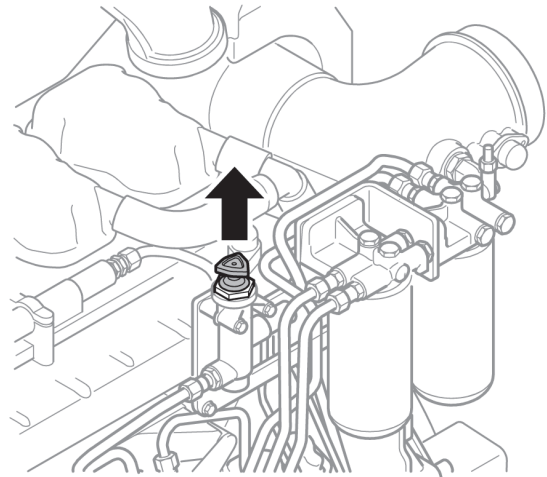

2. Attach a clear plastic hose to the ventilating valve on the prefilter
3. Place the other end of the plastic hose in a container that holds at least 5 litres (1.3 US gallons).
4. Open the ventilating valve.
5. Pump with the hand pump until fuel without air bubbles comes out.
6. Close the ventilating valve.

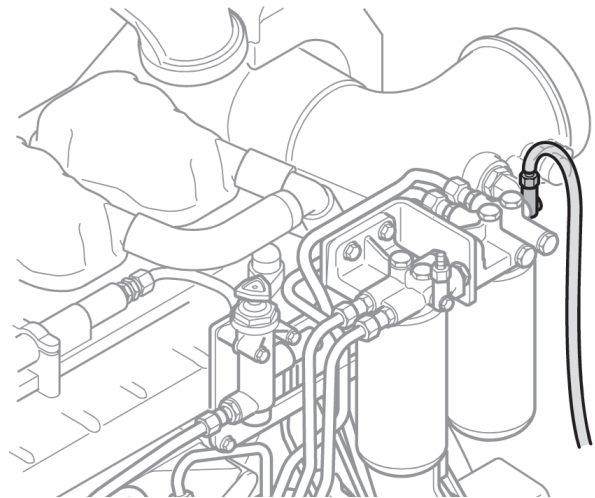

7. Connect the plastic hose to the ventilating valve on the main filter.
8. Open the ventilating valve.

S08 MAINTENANCE

9. Pump with the hand pump until fuel without air bubbles comes out.

10. Close the ventilating valve.

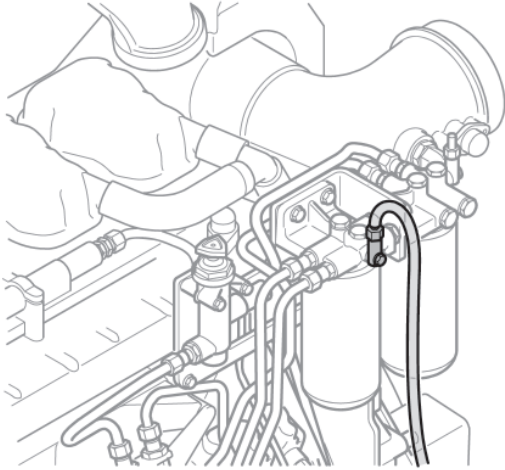

14. Close the ventilating valve and screw the hand pump handle downwards.

15. Start the engine. The engine should be easy to start.

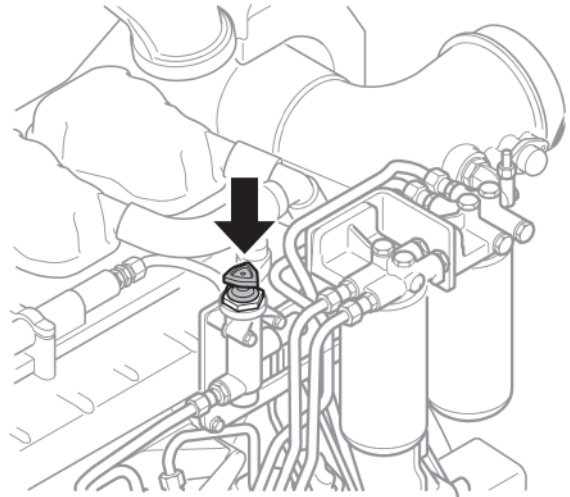

11. Connect the plastic hose to the ventilating valve in the high pressure pump.

12. Open the ventilating valve.

13. Pump with the hand pump until fuel without air bubbles comes out of the plastic hose. It will take around 150 pump strokes.

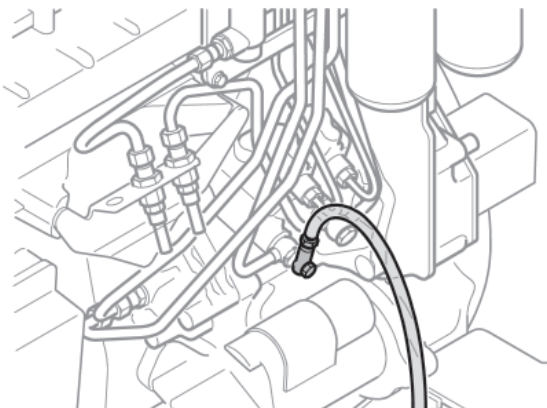

LUBRICATION SYSTEM



CAUTION !

Never over-fill the engine oil crankcase.



NOTE !

With a new or reconditioned engine, oil and oil filters must be replaced earliest after 100 hours of operation. Use oil grades as indicated in the section TECHNICAL DATA.

Warranty claims may be rejected if unsuitable oil grade has been used.

The viscosity may be adapted depending the climatic conditions.

OIL LEVEL - ADDING ENGINE OIL

Check the engine and transmission oil level before starting the engine. The oil level should be within the range indicated on the dipstick, between the Mini and Maxi level.

How to check the oil level:

1. Pull off and wipe the dipstick (in red in the picture below).
2. Re-insert and remove the dipstick.
3. Check that the oil level is between the Mini and Maxi marks.
4. If the level is too low, remove the oil filler cap and add some oil slowly at a time. Wait a few minutes before checking the oil level to allow the oil to get down to the oil pan.

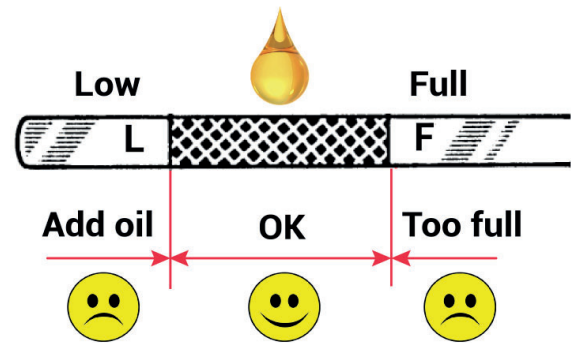
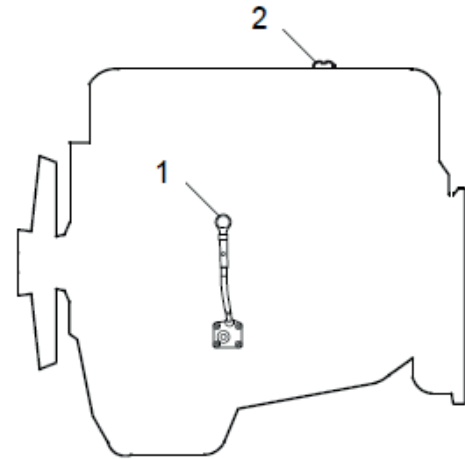

NOTE !

To top up oil level, use the same oil which is in the engine. Do not mix different types of oil.

CHANGING THE OIL



WARNING !

Hot oil can cause burns and skin irritation. Wear protective gloves and eye protection when changing hot oil. Make sure that there is no pressure in the lubrication system before changing the oil. The oil filler cap must always be in place when starting and running the engine to prevent oil being ejected.



NOTE !

Change oil more often if the engine is subjected to particularly demanding operation, such as a dusty environment, or if deposits on the paper in the centrifugal oil cleaner are thicker than 28 mm (1.1 in).

Renew the oil filter and clean the centrifugal oil cleaner when changing oil.

Principle of operation :

1. Unscrew the oil plug and drain the oil when the engine is hot. On some engine types the oil is pumped out by means of a bilge pump. If the engine is drained via the valve, the oil should be hot. Alternatively, use a pump. This so that draining occurs more quickly.
2. Wipe off the magnet on the oil plug.
3. Renew the gasket on the oil plug.
4. Refit the oil plug.
5. Fill with the amount of oil specified for the oil sump.
6. Wait at least 7 minutes.
7. Check the level on the oil dipstick.

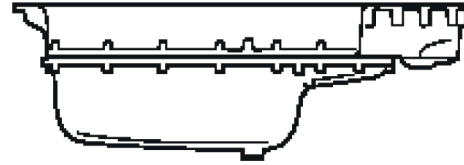

Max. 45 litres (11.9 US gallons).
Min. 39 litres (10.3 US gallons).



Max. 36 litres (9.5 US gallons).
Min. 30 litres (7.9 US gallons).



Max. 34 litres (9.0 US gallons).
Min. 28 litres (7.4 US gallons).

CLEANING CENTRIFUGAL OIL CLEANER



WARNING !

The oil may be hot. Carefully remove the cover from the centrifugal oil cleaner.

Use eye protection and protective gloves when working on the centrifugal oil cleaner.

When the centrifugal oil cleaner is cleaned, there should be some dirt deposits on the paper in the rotor cover. If the paper is clean, the equipment is not working as it should. If this is the case, investigate the cause of this.

Renew the paper more frequently if the dirt deposits are thicker than 28 mm (1.1 inches) during a scheduled oil change.

1. Clean the cover.
2. Unscrew the nut securing the outer cover.
3. Let the oil run out from the rotor.
4. Lift out the rotor. Wipe off the outside.
5. Undo the rotor nut and unscrew it about 1.5 turns.

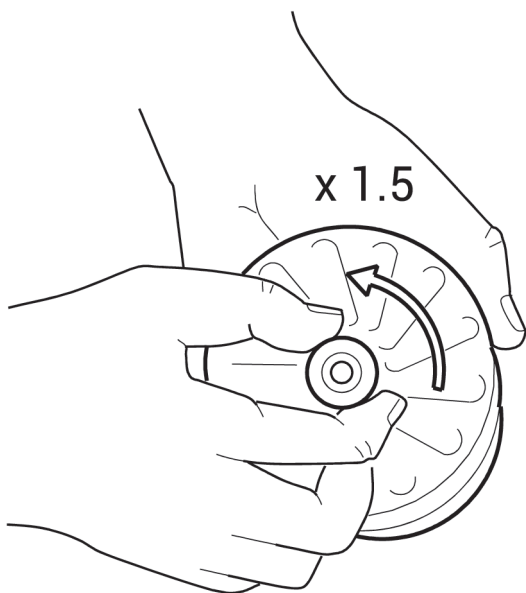

NOTE !

Take care not to damage the rotor shaft.

6. If the rotor nut is jammed: Turn the rotor upside down and fasten the rotor nut in a vice. See illustration.

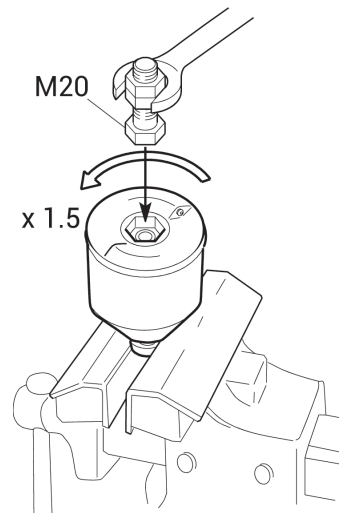

7. Use protective jaws so as not to damage the grooves of the rotor nut.
8. Turn the rotor 1.5 turns anti-clockwise.
9. If this does not work: Screw two nuts together with an M20 screw.
10. Position the screw head at the bottom of the rotor.
11. Position a ring spanner on the lower nut and turn the rotor 1.5 turns anti-clockwise.



IMPORTANT !

Do not attach the rotor directly to the vice. Never strike the rotor cover.

12. Remove the rotor cover by holding the rotor in both hands and tapping the rotor nut against the table. Never strike the rotor directly as this may damage its bearings.
13. Remove the strainer from the rotor cover. If the strainer is stuck, insert a screwdriver between the rotor cover and strainer and carefully prise them apart.

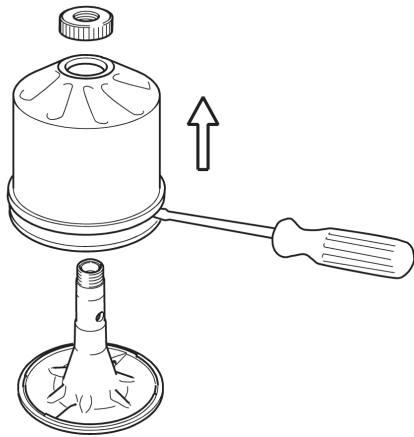

14. Remove the paper insert.

15. Scrape off any remaining dirt deposits from the inside of the rotor cover. If the deposits on the paper are thicker than 28 mm (1.1 in), the centrifugal oil cleaner must be cleaned more often.

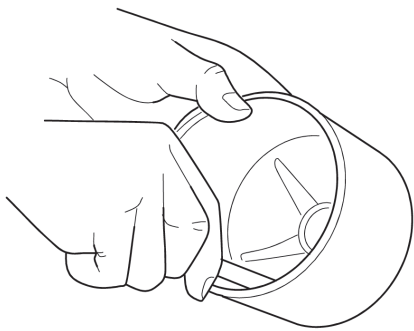

16. Wash the parts according to the applicable industrial method.

17. Inspect the 2 nozzles on the rotor. Ensure that they are not blocked or damaged. Renew any damaged nozzles.

18. Check that the bearings are undamaged. Renew damaged bearings.

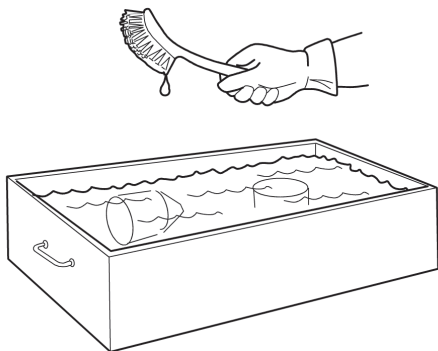

19. Fold and fit a new paper insert (an old marine map would do very well) on the inside of the rotor cover as illustrated.

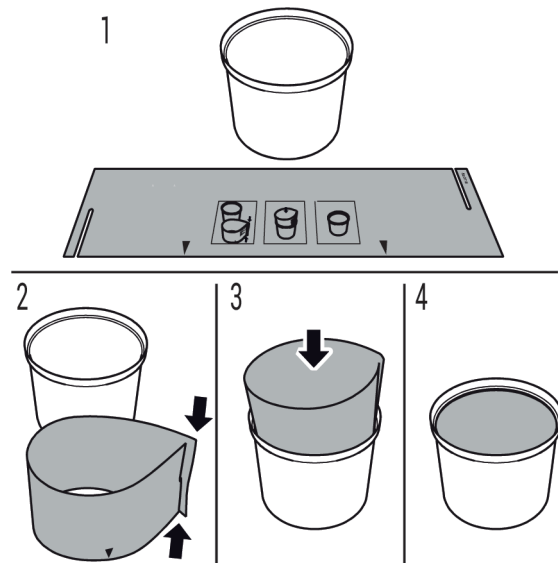

20. Fit the strainer onto the rotor.

21. Fit a new O-ring to the foot of the centrifugal oil cleaner.

22. Refit the rotor cover. Ensure that the O-ring is not outside the edges, but is in the groove.

23. Screw the rotor nut back on by hand.

24. Check that the shaft is not damaged or loose. Contact a Nanni representative if the rotor shaft needs renewing.

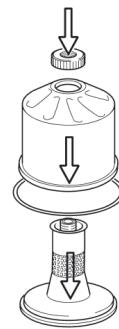

NOTE !

Take care not to damage the rotor shaft.

25. Refit the rotor and rotate it by hand to make sure it rotates easily.

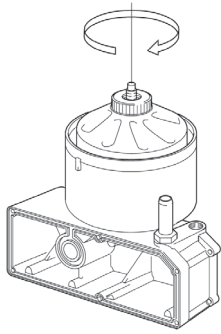

26. Fit a new O-ring in the cover.

27. Refit the cover and tighten the lock nut. Tightening torque 20 Nm (15 lb-ft).

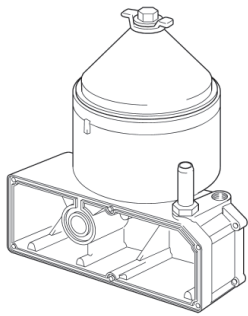

OPERATIONAL TESTING OF THE CENTRIFUGAL OIL CLEANER

Operational testing need only be carried out if it is suspected that the centrifugal oil cleaner is malfunctioning. For example, if there are unusually few deposits given the distance driven.

1. Run the engine until it reaches normal operating temperature.
2. Turn off the engine and listen for the sound from the rotor. It should continue rotating for a time, even when the engine has stopped.
3. Use your hand to feel if the filter housing is vibrating.
4. If the filter housing is not vibrating, dismantle and check the centrifugal oil cleaner.

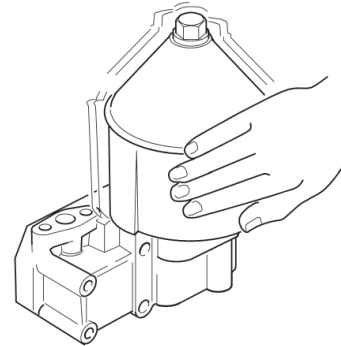

IMPORTANT!

To reduce the risk of oil leakage it is important to tighten the cover to the correct tightening torque.

S08 MAINTENANCE

REPLACE THE OIL FILTER

Clean the centrifugal oil cleaner at the same time as you change the oil filter. Otherwise, the oil filter will be blocked and resistance in the filter will increase. If this happens, an overflow valve in the filter retainer opens and lets the oil pass without being filtered.

1. Remove the old filter.
2. Oil the rubber gasket on the new filter.
3. Tighten the filter by hand. Never use tools because the filter could sustain damage, obstructing circulation.
4. Start the engine and check for leaks.

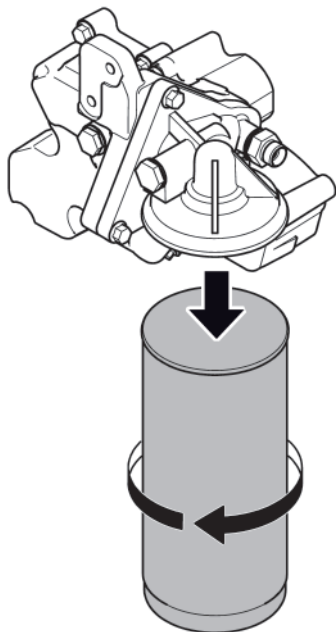

COOLING SYSTEM



CAUTION !

Instead of proper mix coolant, raw clean water can only be used in case of emergency and for the shortest time possible. As soon as back to shore, get in touch with the nearest Nanni representative or seasoned marine shipyard or workshop. Please refer to the Fluids section for complete information.



CAUTION !

- Always use coolant made of 50% antifreeze with anti corrosion additive and 50% of clean water. The antifreeze protects the engine against internal corrosion.
- This mix must be used all year around, even if there is no risk of frost.
- Never use water alone to completely fill the coolant system. Please refer to the Fluids section for complete information.

COOLANT

WATER & ANTI-FREEZE

Please refer to the [Fluids section](#) for complete information.

WATER BOILER

A water boiler can be connected to the engine coolant circuit. If the boiler is located above the engine, an additional recovery tank must be installed above the boiler.

Ducts to the boiler must be in accordance with high temperature and high pressure. Never attempt to use flexible hoses supplied from a hardware store.

A specific boiler kit is available from Nanni Industries. Please contact your nearest Nanni representative for more information.

The amount of coolant must be adapted depending the model of water boiler to completely fill the coolant system.

COOLANT EXPANSION

When the engine is running, the internal temperature is high ; as a result, the coolant liquid expands its volume. The heat exchanger is designed to accomodate this normal and physical expansion.

Make sure not to overfill the heat exchanger when filling with coolant.

S08 MAINTENANCE

CHECKING COOLANT LEVEL



DANGER !

Never open the coolant filling cap or any plug of the cooling system when the engine is operating or still warm. Steam or hot fluid can spray out. Prevent potential injuries ! Use protective gloves as coolant can cause irritation if it comes in contact with the skin.



IMPORTANT !

It is not permissible to top up large amounts of coolant via the expansion tank. Filling via the expansion tank leads to air locks in the cooling system which can lead to e.g. cavitation damage to the coolant pump shaft seal. If a large amount of coolant needs to be added, follow the instructions in the section [Filling coolant](#).

The following instructions apply to Nanni expansion tanks. For other types of expansion tanks, follow the manufacturer's instructions.

1. Check the coolant level through the sight glass on the expansion tank.
2. Top up with coolant as necessary.

CHECKING COOLANT ANTIFREEZE AND CORROSION PROTECTION

Tools

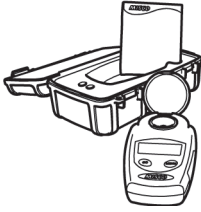
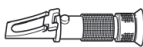
Description	Illustration
Refractometer	
	



WARNING !

Avoid skin contact with coolant as this may cause irritation to the skin. Wear protective goggles and gloves when handling coolant.



IMPORTANT !

Use only pure fresh water that is free from particles, sludge and other impurities.

1. For a small amount of coolant into a container and check that the coolant is pure and clear.
2. Change the coolant if it is contaminated or cloudy.
3. Measure the antifreeze and corrosion inhibitor content with the refractometer.

The following rules apply to ethylene glycol based coolant:

- The antifreeze and corrosion inhibitor content must be minimum 35 percent by volume for corrosion protection to be sufficient.
- An antifreeze and corrosion inhibitor content greater than 55 percent by volume impairs the ability to protect against frost.
- If ice forms in the coolant, there are disruptions initially, but there is no immediate risk of damage. The engine should not be subjected to heavy loads when ice starts to form.

CHECKING SACRIFICIAL ANODES



IMPORTANT !

Corrosion of sacrificial anodes depends on the operating environment. Therefore, check the sacrificial anodes every third month during the first year of commissioning or when changing the operating environment.

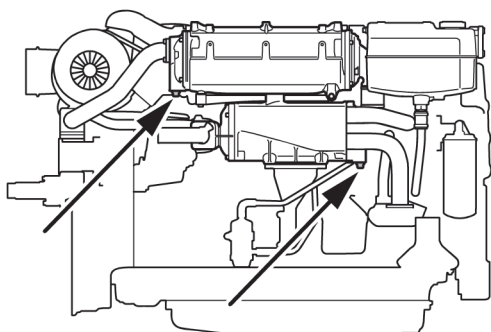

Position of sacrificial anodes.

1. Drain the sea water circuit as described in the [Draining the sea water](#).
2. Remove all sacrificial anodes.
3. Check all sacrificial anodes:
 - * Scrape off all loose material and check the corrosion.
 - * Renew all sacrificial anodes if there is less than $\frac{3}{4}$ (2) remaining of any of the sacrificial anodes.

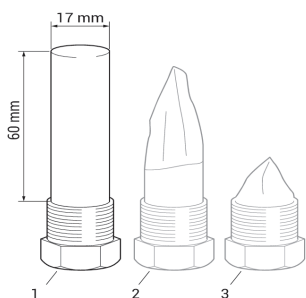

1. New sacrificial anode.
2. Approx. 3/4 remains.
3. Approx. 1/4 remains.

- * If the sacrificial anodes are very corroded (3), the length of the intervals for checking the sacrificial anodes should be halved. If the sacrificial anodes are very corroded, they often come loose entirely.
4. Renew the gasket when fitting.

CHECKING SEA WATER PUMP IMPELLER

1. Drain the sea water circuit as described in the [Draining the sea water circuit](#).
2. Remove the sea water pump cover. See illustration.

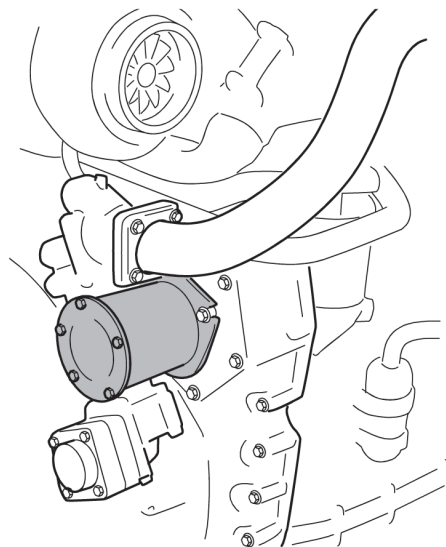

3. Check that the vanes of the impeller are not heavily splintered or damaged.

RENEWING THE SEA WATER PUMP IMPELLER

Special tool

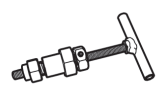
Number	Description	Illustration
965400001	Puller	



NOTE !

If the impeller must be renewed frequently, the cleaning of the sea water needs to be improved.

There should be a spare impeller and puller on board.

The impeller can be deformed during extended periods of inactivity. Renew the impeller before starting or remove the impeller before longer periods of stoppage.

S08 MAINTENANCE

1. Pull out the impeller using the puller. Note the direction of rotation of the impeller vanes.
2. Fit a new impeller and cap. Check that the cap seal is not hard or damaged.

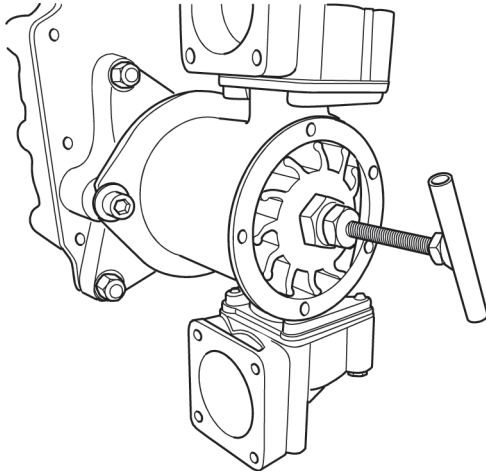

IMPORTANT !

When fitting the new impeller, bend the vanes in the same direction as on the old one.

CHANGING THE COOLANT AND CLEANING THE COOLANT SYSTEM

DRAINING COOLANT

Special tool

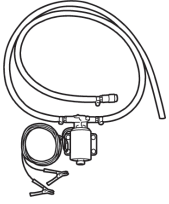
Number	Description	Illustration
965400003	Coolant pump	



WARNING !

Do not open the coolant filler cap in the expansion tank if the engine is hot. Hot coolant and steam may spray out and cause burns. If the cap has to be opened do it slowly to release the pressure before removing the cap. Use protective gloves as coolant can cause irritation if it comes in contact with the skin.

1. Open the expansion tank cap.
2. Position the hose from the coolant pump in an empty container.
3. Connect the pump to the draining nipple in the cylinder block. See illustration.

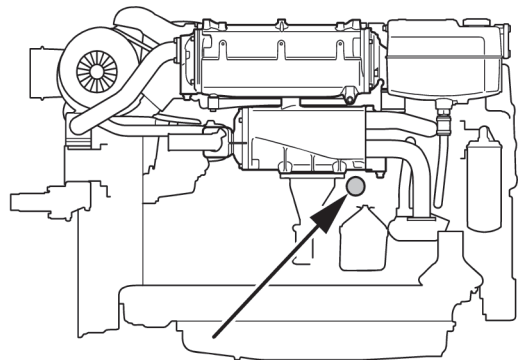

Drain nipple in the cylinder block

4. Connect the pump's 2 cable terminals to the battery's negative and positive terminal. Make sure that the drainage starts. If the drainage does not start: Change the position of the cable terminals.
5. Repeat the procedure at the cooling system's lowest drainage point. The location of the lowest drainage point on the engine may differ depending on engine application.

DRAINING THE SEA WATER CIRCUIT

1. Close the bottom valve on the sea water inlet and remove the connection pipe (1) on the outlet from the heat exchanger.
2. Remove the cover (2) from the sea water pump to empty the pump completely.

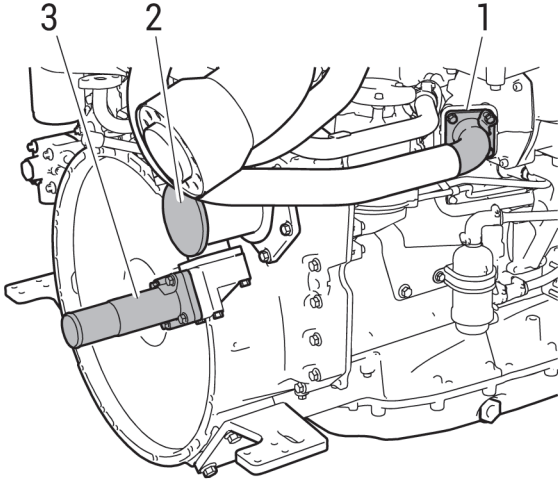

The lowest point in the sea water circuit may be at different points, but it is usually in the sea water pump intake (3).



IMPORTANT !

Plug the connections to prevent dirt ingress into the engine.

REMOVING THE CHARGE AIR COOLER

When the cooler core of the charge air cooler needs cleaning, the charge air cooler must be removed if there is no space behind it to take out the cooler core.

Before starting work : Make sure that the cooling system is empty as described earlier.

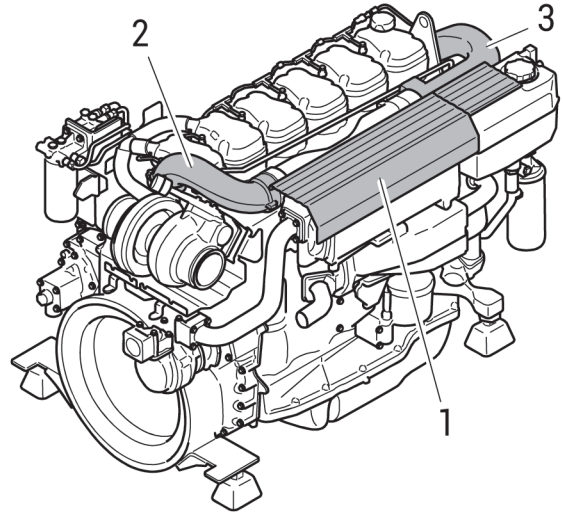

1. Remove the protective plate (1) on the charge air cooler.
2. Remove the charge air pipe (2) between the charge air cooler and the turbocharger. Twist the pipe to facilitate removal. If the turbocharger has a wastegate valve and the charge air pipe must be removed, the pipe bracket must be removed and the pipe must be turned 90° upwards before the hose and the pipe are removed.
3. Remove the charge air pipe (3) between the charge air cooler and the inlet pipe.

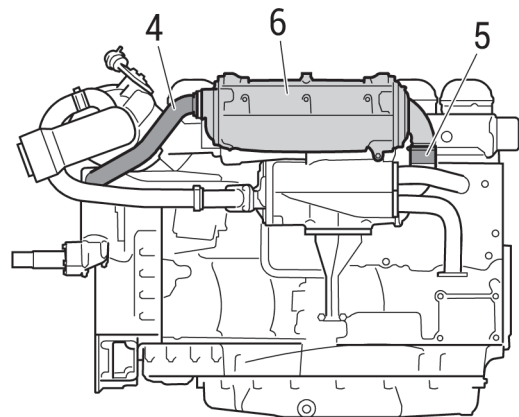

4. Remove the water pipe (4) of the charge air cooler.
5. Release the hose clamp and remove the sea water hose (5) between the charge air cooler and the heat exchanger.
6. Remove the charge air cooler (6).

CLEANING THE CHARGE AIR COOLER

The charge air cooler must be removed if there is no space behind it to take out the cooler core. See previous section.

1. Remove the screws on the charge air cooler covers (1) and remove the covers. Mark the covers so that you can put them back on the correct side.
2. Press in the cooler core (3) slightly on one side and pull it out from the other side.
3. Clean the cooler core on the outside with paraffin-based engine detergent. Remove any internal deposits using a round rod. Renew the cooler core if it is damaged.



IMPORTANT !

Do not use caustic soda as this could damage the aluminium.

4. Renew damaged or hard O-rings (2).
5. Assemble the charge air cooler. Tighten the M8 screws on the covers to 15 Nm (11 lb-ft).

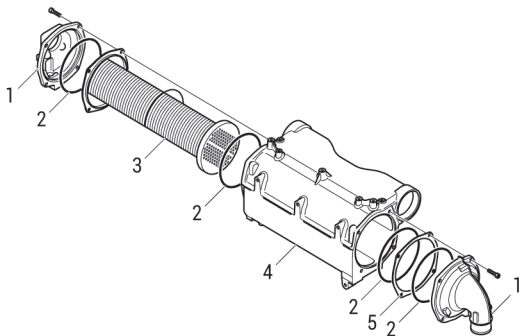

1. Cover.
2. O-rings.
3. Cooler core.
4. Charge air cooler housing.
5. Spacer.

REMOVING THE HEAT EXCHANGER

When the cooler core of the heat exchanger needs cleaning, the heat exchanger must be removed.

Before starting work : Make sure that the cooling system is empty as described earlier.

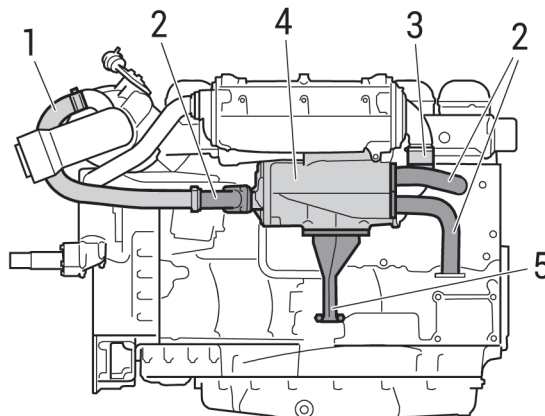

1. Undo the V-clamp for the hose (1) between the heat exchanger and the water-cooled exhaust pipe bend, if the engine has one. Bend the hose to one side.
2. Remove the inlet and outlet coolant pipes and the sea water pipe (2) from the heat exchanger.
3. Release the hose clamp and remove the sea water hose (3) between the charge air cooler and the heat exchanger.
4. Remove the screws holding the heat exchanger (4) in the two brackets.
5. Slacken the screws holding the heat exchanger bracket (5) in the cylinder block sufficiently to allow the heat exchanger to be removed.
6. Remove the heat exchanger.

CLEANING THE HEAT EXCHANGER

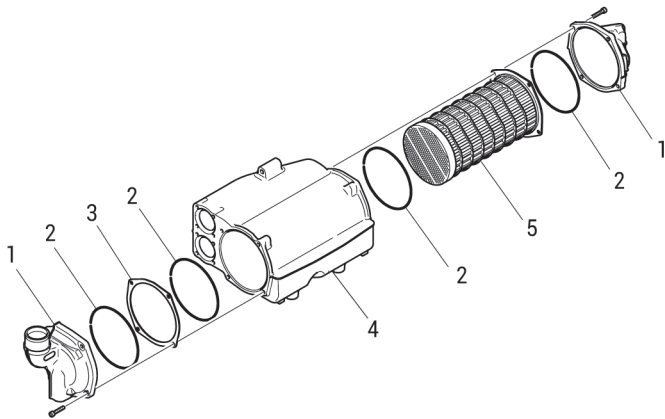

1. Cover.
2. O-rings.
3. Spacer.
4. Heat exchanger housing.
5. Cooler core.

1. Remove the screws on the heat exchanger covers (1) and remove the covers. Mark the covers so that you can put them back on the correct side.
2. Press in the cooler core (5) slightly on one side and pull it out from the other side.
3. Clean the cooler core on the outside with paraffin-based engine detergent. Remove any internal deposits using a round rod. Renew the cooler core if it is damaged.



IMPORTANT !

Do not use caustic soda as this could damage the aluminium.

4. Renew damaged or hard O-rings (2).
5. Assemble the heat exchanger. Tighten the M8 screws on the covers to 15 Nm (11 lb-ft).

FITTING THE HEAT EXCHANGER



IMPORTANT !

There is a risk that the joint will crack if these installation instructions are not followed.

Tightening torque:

- M6 10 Nm (7 lb-ft)
- M8 26 Nm (19 lb-ft)
- M10 50 Nm (37 lb-ft)

1. Fit the heat exchanger (4) in place against the brackets.
2. Fit the sea water hose (3) between the heat exchanger and charge air cooler (use vaseline if necessary) and tighten the hose clamp.

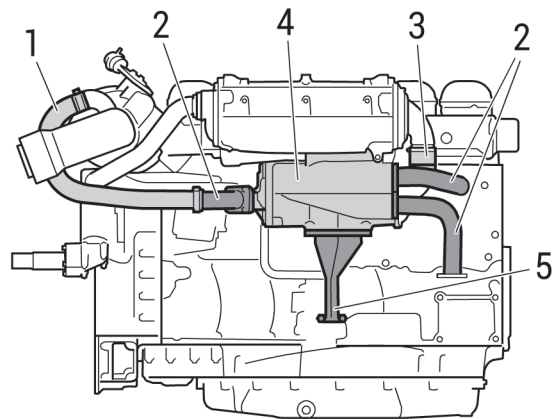

IMPORTANT !

To prevent leakage, a hose clamp with a safety ring can be used.

3. Fit the screws (5 off) securing the heat exchanger without tightening them.
4. Tighten the screws securing the heat exchanger bracket (5) in the cylinder block.
5. First tighten the screw on the charge air cooler bracket and then the 4 screws on the heat exchanger bracket.
6. Fit the inlet and outlet coolant pipes and the sea water pipe from the heat exchanger (2).

- Fit the hose (1) between the heat exchanger and the water-cooled exhaust pipe bend and tighten the

FITTING THE CHARGE AIR COOLER

Tightening torque :

- M6 10 Nm (7 lb-ft)
- M8 26 Nm (19 lb-ft)
- M10 50 Nm (37 lb-ft)

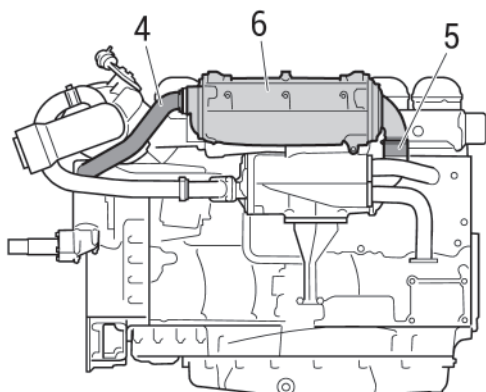

- Fit the charge air cooler (6) in place against the brackets.
- Fit the sea water hose (5) between the charge air cooler and heat exchanger (use vaseline if necessary) and tighten the hose clamp.
- Fit the screws for the charge air cooler brackets and tighten them.
- Fit the water pipe (4) between the water pump and the charge air cooler.

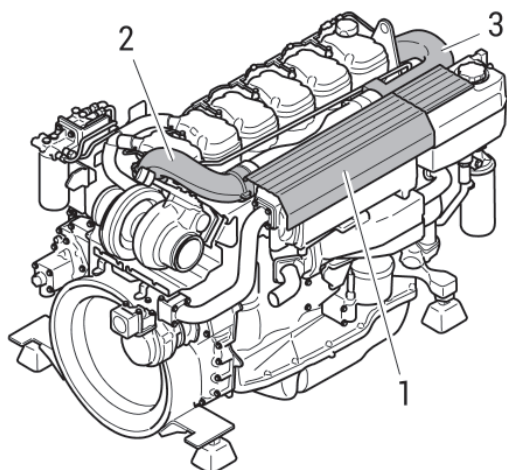

- Fit the charge air pipe (3) between the intake manifold and charge air cooler. To facilitate fitting, lubricate the O-ring and the inside of the connection in the charge air cooler with vaseline. Press the charge air pipe straight towards the charge air cooler while carefully twisting the pipe to the right and left. Check that the charge air pipe is properly fitted.
- Fit the charge air pipe (2) between the charge air cooler and turbocharger. To facilitate fitting, lubricate the O-ring and the inside of the connection in the charge air cooler with vaseline. Press the charge air pipe straight towards the charge air cooler while carefully twisting the pipe to the right and left. Check that the charge air pipe is properly fitted.
- Fit the protective plate (1) on the charge air cooler.

INTERNAL CLEANING: REMOVING OIL AND GREASE FROM COOLING SYSTEM

Always fit a new thermostat and a new cover to the expansion tank after cleaning, as the oil in the cooling system destroys the seals. If the engine is equipped with a coolant filter, also renew this filter.

It may be necessary to wash it multiple times if the cooling system is very dirty. One cause of contamination can be that oil is lying on top of the coolant and collecting high up in the cooling system. If several rinses are needed, this is not necessarily because work has been carried out incorrectly. Oil residues often need to be rinsed repeatedly from the expansion tank and the external heating system to be completely clean.

Repeated washing is more effective and preferable to using higher concentrations of detergent (max. 10%) or cleaning for a longer period (max 30 minutes).

If only a small amount of dirt has been collected in the expansion tank after cleaning, one extra rinse and clean of the expansion tank only is usually sufficient. There is no need to clean the whole cooling system again.

- Run the engine until it has reached operating temperature and drain the cooling system following the previous description.
- Remove the thermostat.
- Fill the cooling system with clean, hot water mixed with a dishwasher detergent for household dishwashers that does not foam. Concentration 1%.

4. Run the engine until it has reached operating temperature for approximately 20-30 minutes. Remember to switch on the cab heating system, if one is installed.
5. Drain the cooling system.
6. Fill the cooling system with clean, hot water and run the engine for about 20-30 minutes.
7. Repeat steps 3-6 if the cooling system is not clean.
8. Drain the water from the cooling system.
9. If necessary, clean the expansion tank by detaching all hoses and rinsing and cleaning with a degreasing agent and a dishwashing brush. Alternatively, dismantle the expansion tank and clean it with water with 10% of dishwasher detergent does not foam. Fill the expansion tank with the mixture, shake it around and drain it. Renew the cover of the expansion tank.
10. Fit a new thermostat.
11. Fill the cooling system with new coolant as described in the next section.
12. Check again whether further dirt or oil has collected in the expansion tank. Decide whether it is necessary to carry out another full cleaning or whether only rinsing or cleaning of the expansion tank will suffice.

INTERNAL CLEANING: REMOVING DEPOSITS FROM COOLING SYSTEM

1. Run the engine until it has reached operating temperature and then drain the cooling system following the previous description.
2. Remove the thermostat.
3. Fill the cooling system with clean, hot water mixed with radiator detergent which is based on sulphamic acid and contains dispersing agents. Follow the manufacturer's instructions for the concentration and cleaning period.
4. Run the engine for the specified time. Remember to switch on the cab heating system, if one is installed.
5. Drain the cooling system.
6. Fill the cooling system with clean, hot water and run the engine for about 20-30 minutes.
7. Drain the water from the cooling system.
8. Reinstall the thermostat.
9. Fill the cooling system with new coolant as described in the next section.

FILLING COOLANT

This procedure applies when the cooling system has been drained and needs to be filled with a large amount of coolant.

Special tool

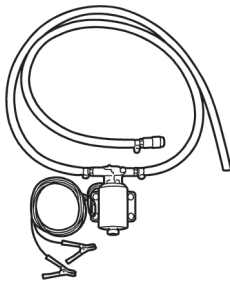
Number	Description	Illustration
965400003	Coolant pump	



WARNING !

Use protective gloves as coolant can cause irritation if it comes in contact with the skin. Hot coolant can also cause scalding.



IMPORTANT !

Mix the coolant as specified in the section headed **Coolant**.

It is not permissible to top up large amounts of coolant via the expansion tank. Filling via the expansion tank leads to air locks in the cooling system which can lead to e.g. damage to the coolant pump shaft seal. If a large amount of coolant needs to be added, follow the instructions in the section **Filling coolant**.

Never fill a large amount of cold coolant in a hot engine. There is great risk of cracks forming in the cylinder block and cylinder heads.

Do not start the engine until the correct coolant level has been obtained. If the engine is started with an insufficient coolant level, it can damage the coolant pump shaft seal, which leads to coolant leakage.

1. Open the expansion tank cap.
2. Connect the coolant pump to the filler nipple in the cylinder block.
3. Connect the pump's 2 cable terminals to the battery's negative and positive terminal. Make sure that the filling starts. If the filling does not start: Change the position of the cable terminals.
4. Start the engine and run it at idling for 15 minutes.

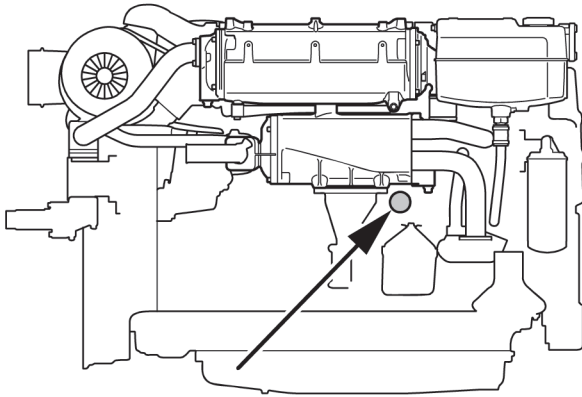

Filler nipple in the cylinder block



IMPORTANT!

It is very important that the engine is idling. Engine overspeed could damage the coolant pump shaft seal, which leads to coolant leakage.

5. Switch off the engine and fill with coolant to the maximum level through the expansion tank.



NOTE!

Air pockets may still be left in the cooling system. These will disappear after the engine has been operated for a period of time.

Therefore, the coolant may need topping up at a later stage.

FINISHING WORK

1. Open the bottom valve on the sea water inlet.
2. Start the engine and check that no leakage occurs.

Check the coolant level and top up the coolant via the expansion tank if necessary.

MAXIMUM TILT ANGLES DURING OPERATION

Maximum permissible angles of inclination during operation vary, depending on the type of oil sump. See illustration.

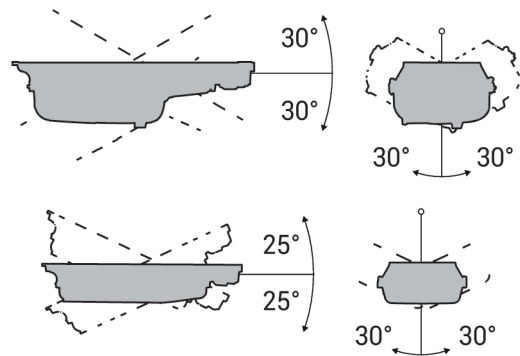

ELECTRICAL SYSTEM



DANGER !

Stop the engine and switch off the main breaker before working on the electrical system. Isolate shore current to any accessories supplying the engine.



CAUTION !

The main breaker switch must remain ON when the engine is operating. Never disconnect the cable between the alternator and the battery when the engine is running.

WIRES AND CONNECTORS

Check that electrical wires and connectors are dry and in good condition. Replace any defective part. Do not scrape green deposits on lugs in using grit : nickel plating would be removed and bare copper would corrode even faster. Tighten time to time all terminals secured by screws. Do not forget breakers in the electrical cabinet.

To avoid any risk of electromagnetic interference, it is recommended that all electrical cables inside the system be twisted in pairs with 35-40 cables / m. This recommendation applies only to external signal cables connected to the system.

If a shielded electrical cable is used, the shield must be grounded and not 0V ground. Ground pin 3 of beam-beam connector C1 of the main display. See Main Display (DCU), Connections. Only connect the shield to one end of the power cable.

To ensure good separation of electromagnetic interference that may occur, some electrical cables may be routed separately from each other, e.g. the signal cable from a magnetic pulse sensor. The electrical cables of the power supply of the auxiliary display must have a cross section of at least 1.5 mm² and be connected to a fuse of their own, powered directly from the battery.

The main display receives its power supply from the connection box.

Separate the mass and 0 V. In marine installations, the mass and the 0 V must not be connected. The hull is the ground and the negative terminal of the battery is 0 V.

24 V and 0 V are filtered in the main display to reduce electromagnetic interference. If the mass and 0 V are connected, the filters in the main display do not work.

ENGINE COMMAND CONNECTORS

Engine block is linked to the communication box via two cables. These are corresponding to :

C4001 (Engine) = C5 (Box) = CAN

C4002 (Engine) = C6 (Box) = Throttle

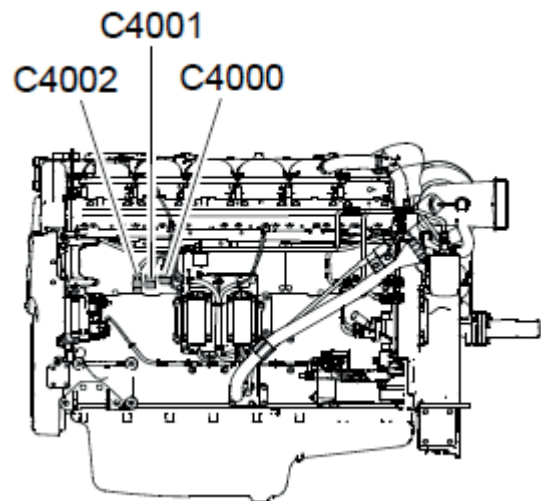

BATTERY



DANGER!

Disconnect the battery cables before contemplating any kind of soldering work. Arc welding is a carrier of heavy transients currents and may affect (or destroy) many sensitive electronic components such as the E.C.U.



Read below recommendations before operating or servicing the battery.

To charge two independent batteries with a single alternator, an isolator is available as an option on most engines. Contact an authorized Nanni representative.

KEEP CLEAN THE BATTERY

The Battery(ies) should be kept clean and dry. Oxidization deposits on the battery and on terminals posts may lead to a wide variety of disturbances like: dead shorts, voltage drops, premature discharging, notably in wet or cold weather. In some occurrences, these disturbances may be hard to locate. Use a brass brush to clean battery terminals posts.

DISCONNECT THE STARTER CABLES

1. Disconnect the negative cable (-) first.
2. Then remove the positive (+) cable.

If the battery is replaced, make sure that the previous one was the correct model.

CONNECT THE CABLES

1. Always connect first the positive lead (+) to the positive terminal (+) of the battery
2. And then the negative (-).

BATTERY ELECTROLYTE LEVEL



DANGER!

Never touch the battery electrolyte with bare fingers. The diluted sulphuric acid solution burns skin and will pierce clothing. Should this occur, immediately wash garments with spring water. Obtain medical advice and assistance without delay for burns.

S08 MAINTENANCE

ELECTROLYTE LEVEL CHECK

In general, detailed informations for service provided by battery manufacturers are very scarce. As a conservative rule, electrolyte level must always be above the top of the lead plates (+/-1 cm - slightly less than half of an inch). Electrolyte is a mix of sulphuric acid and water. If level is decreasing, acid concentration is not supposed to deplete with evaporation. Water alone must be added, but it is a good practice to check also the specific gravity with a hydrometer. Follow these indications :

Unscrew completely the vent plugs and check level with a flashlight in each and every orifice.

Use a syringe filled with distilled water to top up the compartment where electrolyte level is too low.

Check gravity in each cell. A reading below 1.215 requires either charging the battery or to replace it.

If the lead plates are not sulphated and still in good condition, charging will improve specific gravity.

Specific Gravity	Charge
1.260	100%
1.230	75%
1.200	50%
1.170	25%
1.140	Very low capacity
1.110	Discharged

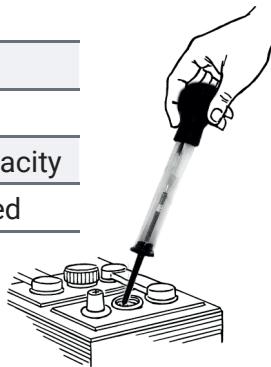

If the battery electrolyte level cannot be adjusted (maintenance free battery type), do not use or charge the battery if the fluid level is below the lower limit level.

If the battery has been left unattended for an extended period of time, it is likely that the battery has entered in a deep discharge process. In such a case, voltage read would be around 7 Volts or so.

Nevertheless, if a new compatible battery is not available at the nearest selling store, it is possible to try this (without any guarantee) :

- Empty the electrolyte,
- Rinse the battery with spring water,
- Empty the spring water and fill with distilled water,
- Give a several hours charge,
- Empty the water,
- Fill the battery with new electrolyte ready to use,
- Charge the battery.



NOTE !

Never shake the battery during the process of adding electrolyte !

MISCELLANEOUS

DRIVE BELT

The engine alternator is driven by a belt through pulleys. These components must be in good order at all times in view for the alternator to provide electricity, among others, to the engine, to the battery, to the engine control panel.



DANGER !

Stop the engine and remove the key before checking or servicing the alternator belt.



NOTE !

Always keep a spare replacement belt on-board.



IMPORTANT !

A loosen or damaged belt can result in overheats or lack of alternator charge. A too tighten belt can damage the bearings of the water pump and of the alternator.

Before starting, make a note of how the drive belt is fitted. Refit the drive belt with the same direction of rotation as it had before removal.

1. Check the drive belt for cracks. Renew the drive belt if deep cracks have formed.

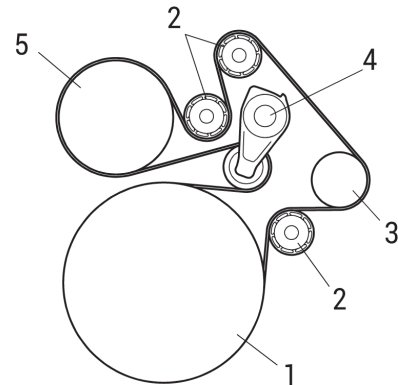

Example of a drive belt.

1. Crankshaft.
2. Idler roller.
3. Alternator.
4. Belt tensioner.
5. Coolant pump.



NOTE !

Small and shallow cracks are normal and form after only a few hours of operation. They do not mean that the drive belt needs to be renewed. If there are many deep cracks, or if parts of the drive belt have started to come off, the drive belt must then be renewed.

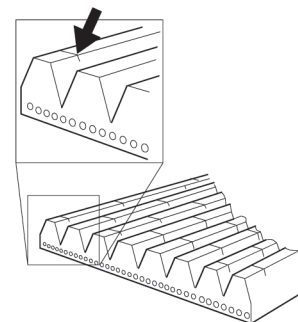

Example of a minor crack in the drive belt. The drive belt can be refitted.

CHECKING FOR LEAKS

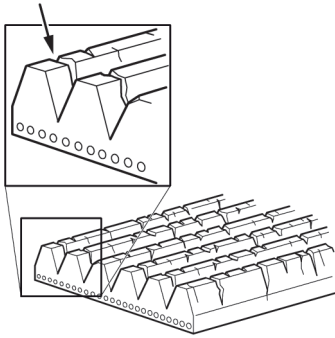

The drive belt has deep cracks and must be renewed.

2. Check drive belt wear. Renew the drive belt if it is too worn.

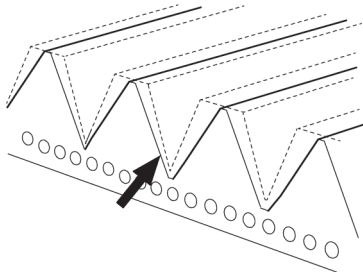

The drive belt is starting to become worn, but can be refitted.

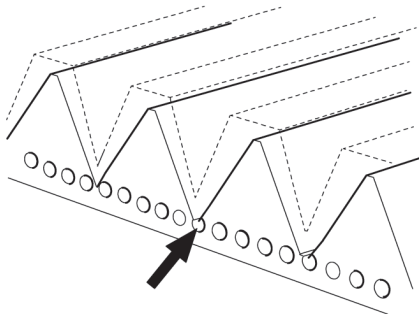

The belt is worn down to the cord. The drive belt must be renewed.



IMPORTANT!

If serious leakage occurs, contact your nearest NANNI representative.

1. Start the engine.
2. Check for oil, coolant, fuel, air or exhaust leaks.
3. Tighten or renew leaking connections. Check the overflow holes which show whether the O-rings between the cylinder liners and crankcase are leaking.
4. Check whether the drain hole on the coolant pump is blocked. If there is a leak, renew the seal in the pump or the complete coolant pump.

S08 MAINTENANCE

CHECKING AND ADJUSTING THE VALVE CLEARANCE

Special tools

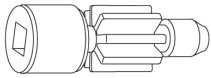
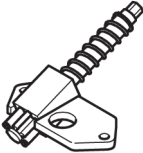
Number	Description	Illustration
965400004	Turning tool for rotating the flywheel from below	
965400005	Turning tool for rotating the flywheel from above	

Other tools

Torque wrench, 0-50 Nm
Waterproof felt-tip pen
Feeler gauge 0.45 and 0.70 mm
Flash light
Mirror



WARNING !

Block the starting device or remove a battery cable. If the engine starts unexpectedly, there is a serious risk of injury.



IMPORTANT !

The engine must be cold when the work is carried out. Remember to remove the turning tool from the flywheel after adjustment.



NOTE !

Carry out the working without pausing, so that no step is overlooked.

Carry out a check and adjustment of the valve clearances one more time after the first 500 hours of operation. After this, adjustment according to the regular interval takes place, which is every 2,000 operational hours.

On the flywheel is engraved the reference information UP TDC, DOWN TDC and the angle indications listed in the table below. Depending on the engine installation, this information is visible in one of the windows, either furthest up or furthest down on the flywheel. See illustration.

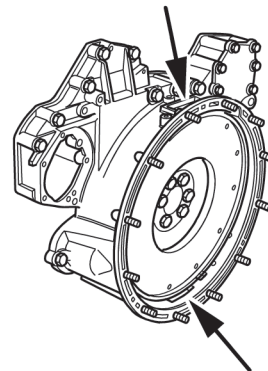

Upper and lower window to read the engraving on the flywheel.

Valve clearance, specifications	
Intake valve	0.45mm (0.018 in)
Exhaust valve	0.70mm (0.028 in)

Tightening torques	
Lock nut for valves	35 Nm (26 lb-ft)

Adjust valves according to the table below. Follow the respective column depending on whether you are reading the engraving on the flywheel in the lower or the upper window. Start adjustment at the top of the table.

Reading in the lower window	Valve transition on cylinder	Adjust valves on cylinder	Reading in the upper window
DOWN TDC	6	1	UP TDC
120/480	2	5	300/660
240/600	4	3	60/420
DOWN TDC	1	6	UP TDC
120/480	5	2	300/600
240/600	3	4	60/420

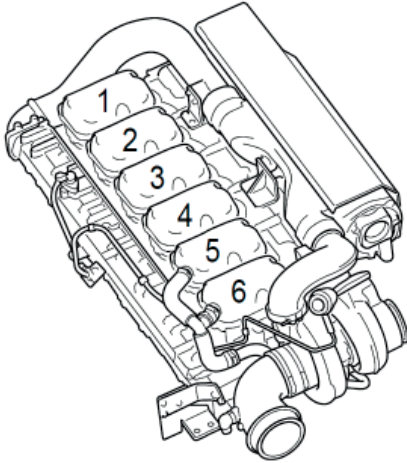

Order of cylinders

1. Clean the rocker covers and the area around them.
2. Remove the rocker covers.
3. Use the turning tool appropriate to the installation of the engine. Tool 99 309 (or equivalent from other suppliers) is used to rotate the flywheel from the underside of the engine and tool 2 402 509 (or equivalent from other suppliers) is used from the top side.

4. Start adjusting one cylinder according to the table. Rotate the flywheel until the correct engraving can be read on the flywheel. It may be necessary to rotate it more than 1 revolution.

Rotate the flywheel in the rotational direction of the engine, which is clockwise viewed from the front of the engine and anticlockwise viewed from the back of the engine.

During a valve transition, the exhaust valve (the long arm) is closing at the same time as the intake valve is opening.

The UP TDC engraving on the flywheel is now visible in the window furthest up on the flywheel. The DOWN TDC engraving is visible in the lower window.

5. Read the table on the previous page to see which valve to adjust.
6. Stick the feeler gauge under the pressure pad of the rocker arm and check the valve clearance.

7. If necessary, adjust the valve clearance by
 - a) loosening the lock nut on the end of the rocker arm
 - b) adjusting the valve clearance with the adjusting screw
 - c) tightening the lock nut.
8. Mark the rocker arm with the felt-tip pen and then continue with the next cylinder according to the table.

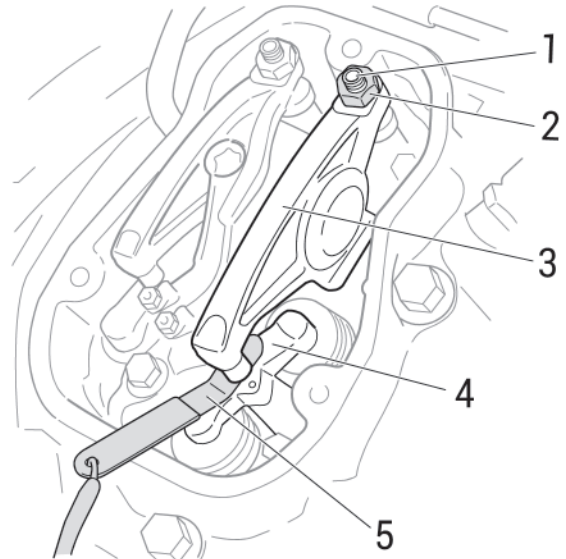

1. Adjusting screw
2. Lock nut
3. Rocker arm
4. Valve bridge
5. Feeler gauge

LONG TERM STORAGE

A set of operations must be performed to prepare and protect the engine for a long-term storage.

See the Maintenance Section 08 - Raw water System - Risk of icing conditions / Protection against frost, to perform some of the Long Term Storage operations. We recommend that you have all these operations carried out by a Nanni authorized workshop.



NOTE !

It might be necessary to adapt these operations depending on the climatic conditions. Contact a Nanni authorized workshop for further information.

For a prolonged storage (over 12 months), a specific set of measures must be performed. All these operations should be carried out by a Nanni authorized workshop.



CAUTION !

If the engine is likely to be subject to frost, drain all water in the seawater circuit.

LONG TERM STORAGE PROCEDURE

Complete the nearest periodic maintenance inspections and operations before performing the long term storage procedure.

1. Drain and change the engine and transmission oil.
2. Change the engine oil filter.
3. Change the fuel filter and prefilter.
4. Run the engine to normal operating temperature.
5. Stop the engine and take the boat out of water.
6. Drain and clean all components of the seawater system. Protect the components against corrosion.
7. Remove the impeller from the seawater pump (if fitted). Store it in a cool and dry place. Indicate by any means that the impeller has been removed.
8. Check the engine coolant level and condition. Top up if necessary.
9. Drain any water and contaminants from the fuel tank.
10. Fill totally the fuel tank.
11. Remove the air filter. Secure all air intake with clean clothes.
12. Clean the engine. Repair any damaged areas of paintwork with Nanni original paint.



CAUTION !

Do not point a high pressure water jet toward seals, hoses, grommets, etc.

13. Clean the hull, the hold and the drive (if fitted).
14. Check all control cables. Use grease and rust inhibitor to protect the cables.
15. Disconnect battery leads. Adjust electrolyte level if necessary. Charge the battery. Store the battery in a dry place.
16. Release tension on belts.
17. Spray the engine with water-repellent product.
18. Remove the propeller for storage. Check the overall condition of all components of the propulsion system.

RESTARTING THE ENGINE

1. Perform external cleaning of the engine and control its condition.
2. Drain and change the engine and transmission oil.
3. Change oil filters.
4. Drain the coolant from the seawater system.
5. Check the condition of the raw water pump impeller. Change it if needed. Install the impeller.
6. Remove cloth and tape from openings. Install the air filter.
7. Close/Tighten all plugs and drain cocks.
8. Check the condition of hoses and clamps.
9. Check the engine coolant level and its condition. Top up if necessary.
10. Connect fully charged batteries.
11. Check the anodes.
12. Install the propeller.
13. Check the operation of the control cables and their condition.
14. Check belts. Adjust the tension.
15. Bleed the fuel system.

Once the boat is in the water:

16. Open the sea cock and prime the seawater system (if fitted).
17. Start the engine. Check for leaks and correct operation.

BATTERY

When storing the engine, adjust the battery electrolyte level and store it in a dry place at room temperature. Recharge the battery as often as possible to extend its service life.

Do not left the battery unattended for a long period of time: it will get into deep discharge (around 7-8 Volts). In such a situation, the battery will not recover.

S10 TROUBLESHOOTING



CAUTION !

If the engine does not function properly, use the following chart to identify the cause. If the cause of trouble can not be found, contact to Nanni authorized workshop.



NOTE !

Some components may not be part of the engine orders. This list is not exhaustive and is only an assistance in case of emergencies.

	PROBABLE CAUSES
The engine fails to start	1, 2, 3, 4, 5, 6, 7, 8, 9, 10, 11, 13
The engine starts but suddenly stops	1, 2, 3, 4, 5
The engine is difficult to start	1, 2, 3, 4, 5, 6, 8, 9
The starter motor is not turning or turn slowly	8, 9
The starter motor turns but the engine does not start	1, 2, 3, 4, 5, 6, 7
The engine does not reach its rated speed at wide open throttle	2, 3, 4, 5, 6, 7, 12, 14, 15, 16, 17, 26, 28
The engine operate unevenly	1, 2, 3, 4, 5, 6, 7, 14, 15, 16, 17, 18, 19, 20, 24, 28
The engine vibrates a lot	16, 27
Black exhaust smoke	4, 5, 14, 15, 16, 19, 20, 28, 29
White exhaust smoke	4, 5, 23, 25
High fuel consumption	4, 7, 14, 15, 16, 19, 20, 22, 28
The engine overheats / coolant temperature too high	14, 15, 16, 18, 19, 20, 21, 22, 28
The control lever is hard to operate	12, 14, 15, 16, 17, 26
No shift between ahead and astern	9, 11, 12, 16, 17, 26
Battery charge warning lamp comes on	8, 9, 11, 18

The numbers refer to the possible causes indicated on the following page.

* Contact a Nanni authorized workshop.

S10 TROUBLESHOOTING

1. Lack of fuel
2. Air in fuel system
3. Fuel filter fouled or clogged
4. Fuel do not meet specified standard
5. Water/contaminants in fuel
6. Valve clearance is wrong *
7. Low compression *
8. Insufficient battery charge / Defective battery
9. Faulty electrical cables contact
10. Faulty starter or starter switch *
11. Tripped fuse / Main switch is open
12. Transmission is damaged*
13. Control lever not in neutral / Stop control pulled out
14. Too much load on board
15. Fouling on underwater hull, drive or propeller
16. Defective/incorrect propeller *
17. Faulty operation of control lever / control cables
18. Loosen or damaged belt
19. Incorrect coolant / Low coolant level / Coolant leaks
20. Cooling system does not operate correctly *
21. Faulty thermostat *
22. Sea cock valve closed / Raw water filter clogged
23. Lube oil burns. Excessive oil consumption *
24. Engine oil level too low
25. Engine oil level too high
26. Transmission oil level too low
27. Defective engine mounting *
28. Insufficient air supply *
29. Clogged air filter or lack of air on admission

nanni



ENERGY IN BLUE

NANNI INDUSTRIES S.A.S.

11, avenue Abbé Mariotte
33260 La Teste de Buch

France

TEL +33 (0) 556 22 30 60

www.nannienergy.com

NANNI SRL

Via degli Olmetti, 44/A
00060 Formello – Roma

Italia

TEL +39 06 30 88 42 51

www.nannienergy.com

