

**PROPULSION ENGINE**

## T4.180-Evo3

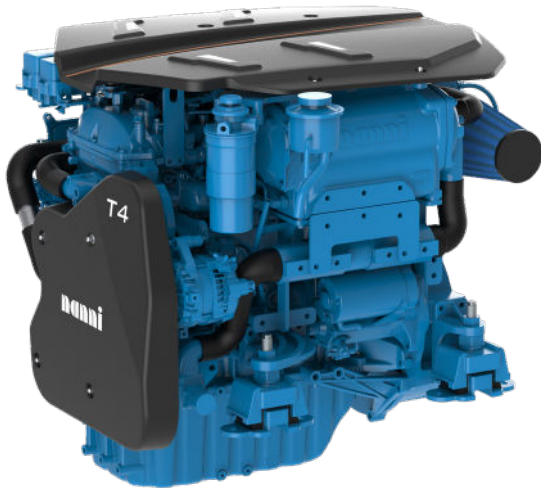

Power at crankshaft	128.7kW [175 hp]
Displacement	2.755 l [168 in <sup>3</sup> ]
Configuration	4 cylinders in line
Operation type	4 strokes Diesel
Bore & Stroke	92 x 103,6 mm [3.62 x 4.07 in]
Compression ratio	15.6 : 1
Rated speed	3200 rpm
Idling speed	700 rpm
Peak torque	500 Nm
Peak torque speed	2000-2200 rpm
Engine base	Toyota
Fuel system	Direct injection Common Rail Electronically controlled
Air intake	Turbocharged with intercooler
Cooling	Closed cooling with heat exchanger
Max mounting angle	7° Front down 7° Front up
Alternator	12 Volt 130 Amp
Rating	M5
Emission compliance	IMO II Annex VI Compliant RCD 2013/53/EU EPA marine Tier 3 BSO2
Dry weight	334 kg [736.3 lbs]

### Engine block

- 4 valves per cylinder
- Dual overhead camshaft (DOHC)
- Watercooled exhaust manifold
- Internal balancers

### Fuel system

- Common Rail injection system
- Fuel filter with hand primer
- Integrated fuel cooler

### Lubrication System

- Replacable full-flow oil filter
- Oil dipstick
- Transmission oil cooler

### Cooling system

- Closed cooling with heat exchanger
- Belt driven self-priming raw water pump
- Coolant circulating pump
- Water cooled exhaust elbow

### Electrical system & instrumentation

- 12 V / 130 A alternator
- 12 V Electrical system
- Complete instrumentation including key switch & alarms
- Extension cable harness with plug-in connection

### Air intake

- Turbocharger
- Intercooler

### Other features

- Flexible engine mountings

### Optional equipments & accessories

- Complete marine propulsion systems
- Marine transmission adaptation kits
- Throttle and shift controls
- Additional instrumentation, Flying bridge extension harness
- Water boiler systems
- Complete fuel systems
- Complete exhaust systems
- Trolling valve
- Switchable Turbine Fuel Prefilter
- Exhaust Muffler & Connections
- Sea water Circuit Kit

### Command Panel SI-5

- Engine RPM
- Oil Pressure
- Water Temperature
- Engine Hours
- Trim Indicator
- Fuel Level
- Nmea 2000
- J1939 CAN BUS



## PROPULSION ENGINE

### Transmission

- ZF68

For other transmission requests, please contact technical support.

### Stern drive

- Bravo X One
- Bravo X Three
- Bravo X Two

### LUBRICATION SYSTEM

Oil pressure @ idle speed	bar	1
	psi	7.3
Oil pressure @ rated speed	bar	4.5
	psi	65.3
Oil quantity excluding filter @ 0° angle	liters	7.5
	gal US	1.98
Maximum permitted installed tilt angle	front down	°7
	front up	°7
Maximum permitted intermittent angle	tilt	°15
	side tilt	°7

### PERFORMANCE

RPM @ cranckshaft	rpm	700	1200	1800	2400	2800	3000	3200	3400
Torque @ cranckshaft	Nm	216.9	252.3	345.4	651.1	586.6	556.4	524.3	436.5
	ft-lb	160	254.8	458.2	480.2	432.7	410.4	386.7	322
Power @ cranckshaft	hp	21.6	43.4	117.1	164.9	172	174.8	175	155.4
	Kw	15.9	31.9	86.1	121.3	126.5	128.6	128.7	114.3
Power at calculated propeller load exp.3	hp	1.9	9.8	33	78.2	124.3	152.8	175	-
	Kw	1.4	7.2	24.3	57.5	91.4	112.4	128.7	-

### FUEL SYSTEM

RPM @ cranckshaft	rpm	700	1200	1800	2400	2800	3000	3200	3400
Fuel consumption propeller load exp.3	l/h	1	1,91	6,46	15,32	24,32	29,92	-	-
	gal US/h	0,26	0,50	1,70	4,04	6,42	7,90	-	-
Fuel consumption at full load	l/h	5	8.2	22.5	30	32	34	29	22
	gal US/h	1.3	2	4.5	6.3	6.9	7.4	7.7	5.8
Maximum permitted fuel inlet pressure	kPa	-30 / +20							
	psi	-4.4 / +2.9							
Maximum permitted fuel return pressure	kPa	20							
	psi	2.9							

## PROPULSION ENGINE

### COOLING SYSTEM

Coolant circulation pump flow	l/min	160
	gal US/min	47.5
Raw water pump flow	l/min	155
	gal US/min	35.1
Total heat rejection at rated speed	kW	124
	BTU/min	-
Total coolant capacity	l	15
	gal US	3.96
Thermostat, start open at	°C	80
	°F	181
Thermostat, fully open at	°C	94
	°F	203

### EXHAUST SYSTEM

Exhaust gas flow	m <sup>3</sup> /min	27.27
	ft <sup>3</sup> /min	963
Permitted back pressure in the exhaust line	kPa	20
	inH <sub>2</sub> O	120.4
Maximum exhaust temperature	°C	550
	°F	1076

### AIR INTAKE SYSTEM

Engine air consumption at 25°C	m <sup>3</sup> /min	12.4
	ft <sup>3</sup> /min	241.5
Maximum allowance intake air temperature	°C	50
	°F	122
Maximum temperature rise, ambient to engine inlet	°C	20
	°F	68
Maximum air intake restriction, clean air filter	kPa	3
	inH <sub>2</sub> O	12
Maximum air intake restriction, dirty air filter	kPa	6.25
	inH <sub>2</sub> O	25.1
Boost pressure	kPa	170-175
	psi	24.6 / 25.3

### ELECTRICAL SYSTEM

Alternator	voltage	V	12
	amperes	A	130
Electric starter motor	kW		2.7
Battery, minimum cold start current	CCA		650 min
Recommended batterie K20	A/h		100 to 120

### DRY WEIGHT

Weight without transmission	kg	334
	lbs	736.3
Dry weight with TTM40A	kg	404
	lbs	859.8

### INSTALLATION TIPS

Fuel line supply diameter	mm	10
	in	0.39
Fuel line return diameter	mm	10
	in	0.39
Sea water line diameter	mm	38
	in	1.5
Exhaust line diameter	mm	104
	in	4.1

### RATINGS

Rating	M5
Operating hours	Up to 1000 annual operating hours
Load Factor	Up to 35 %
Duty Cycle	Full power for no more than 30 minutes out of each 8 hours of operation. The remaining operation time must be at or below cruising speed.

### PROPULSION ENGINE

#### PERFORMANCE CURVES

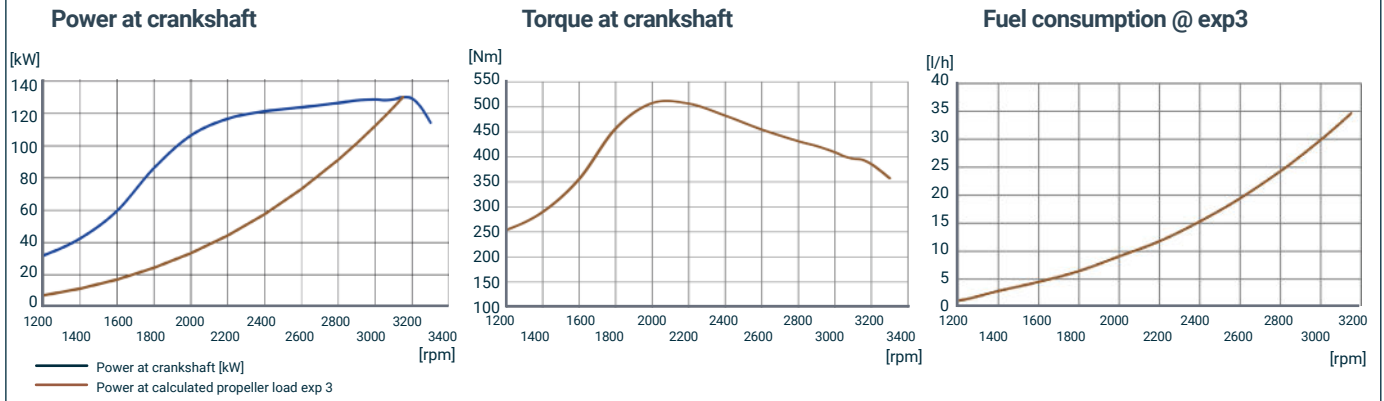

#### DIMENSIONS BOBTAIL

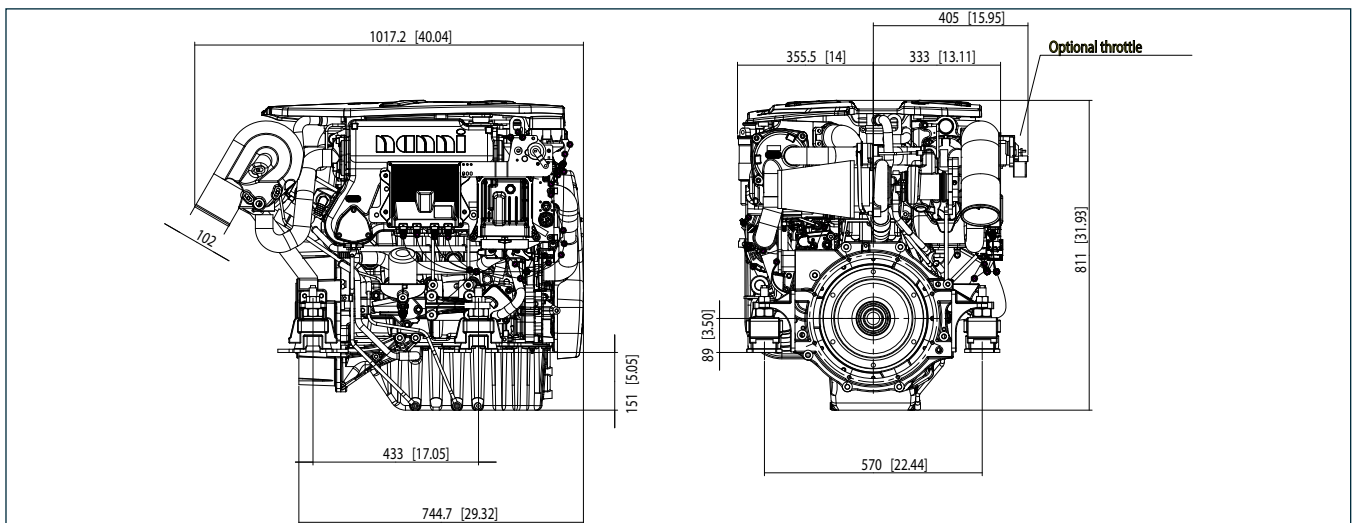

#### DIMENSIONS SHAFT LINE

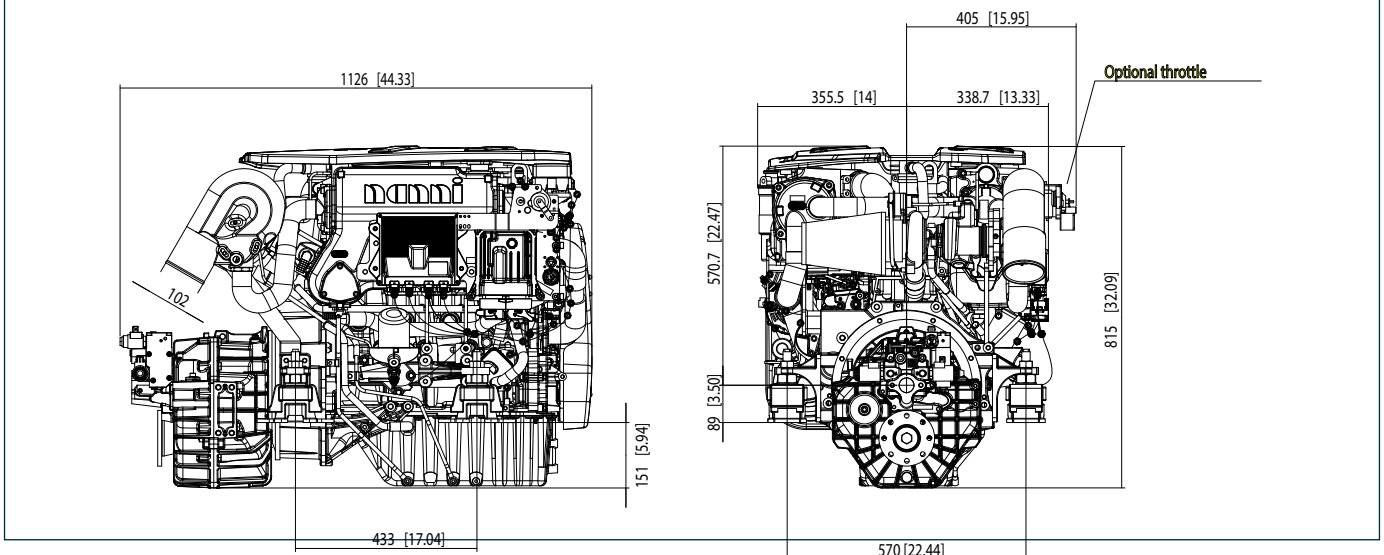

#### DIMENSIONS STERN DRIVE

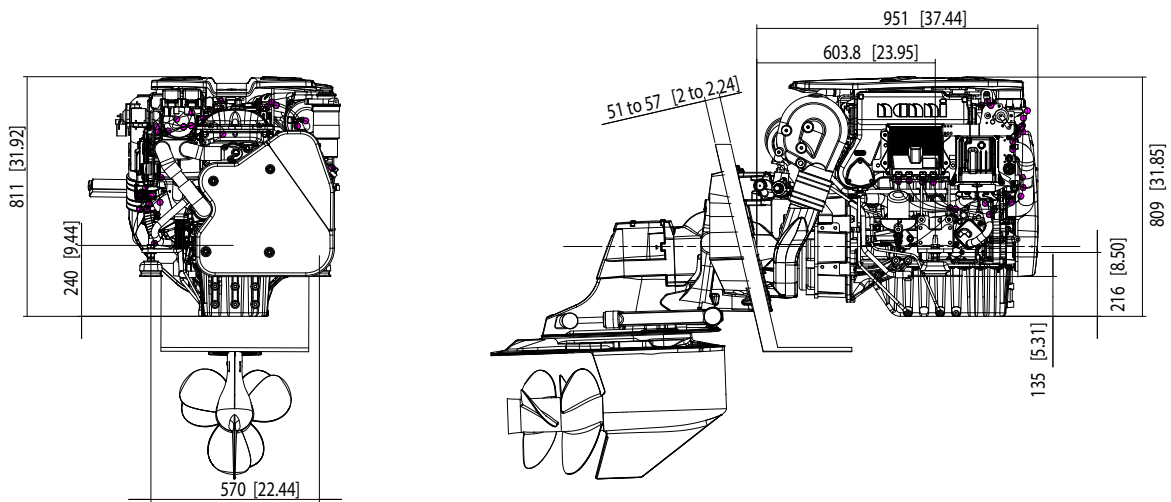

NOTE 1: Dimensions are given in mm [in.].

NOTE 2: data are subject to change without notice. Text and illustrations are not binding. This document is not suitable for vessel installation.

NOTE 3: Technical data according to ISO 8665.

#### AUTHORIZED DISTRIBUTOR

Technical data according to ISO 8665. This document is not contractual. Nanni reserves the right to modify any of the characteristics stated in this document without notice, in a constant effort to improve the quality of its products. Images and illustrations may show non standard equipments. All combination of equipment & accessory are not available.

DGBXXC01072B

#### NANNI INDUSTRIES S.A.S.

11, Avenue Abbé Mariotte  
33260 La Teste - France  
Tel +33 (0)5 56 22 30 60  
[www.nannienergy.com](http://www.nannienergy.com)

#### NANNI SRL

Via degli Olmetti, 44  
00060 Formello - Roma - Italia  
Tel +39 06 30 88 42 51  
[www.nannienergy.com](http://www.nannienergy.com)